

SCHERER PROCESSOR

MODEL: HO

U.S. Patent No. 7,681,384

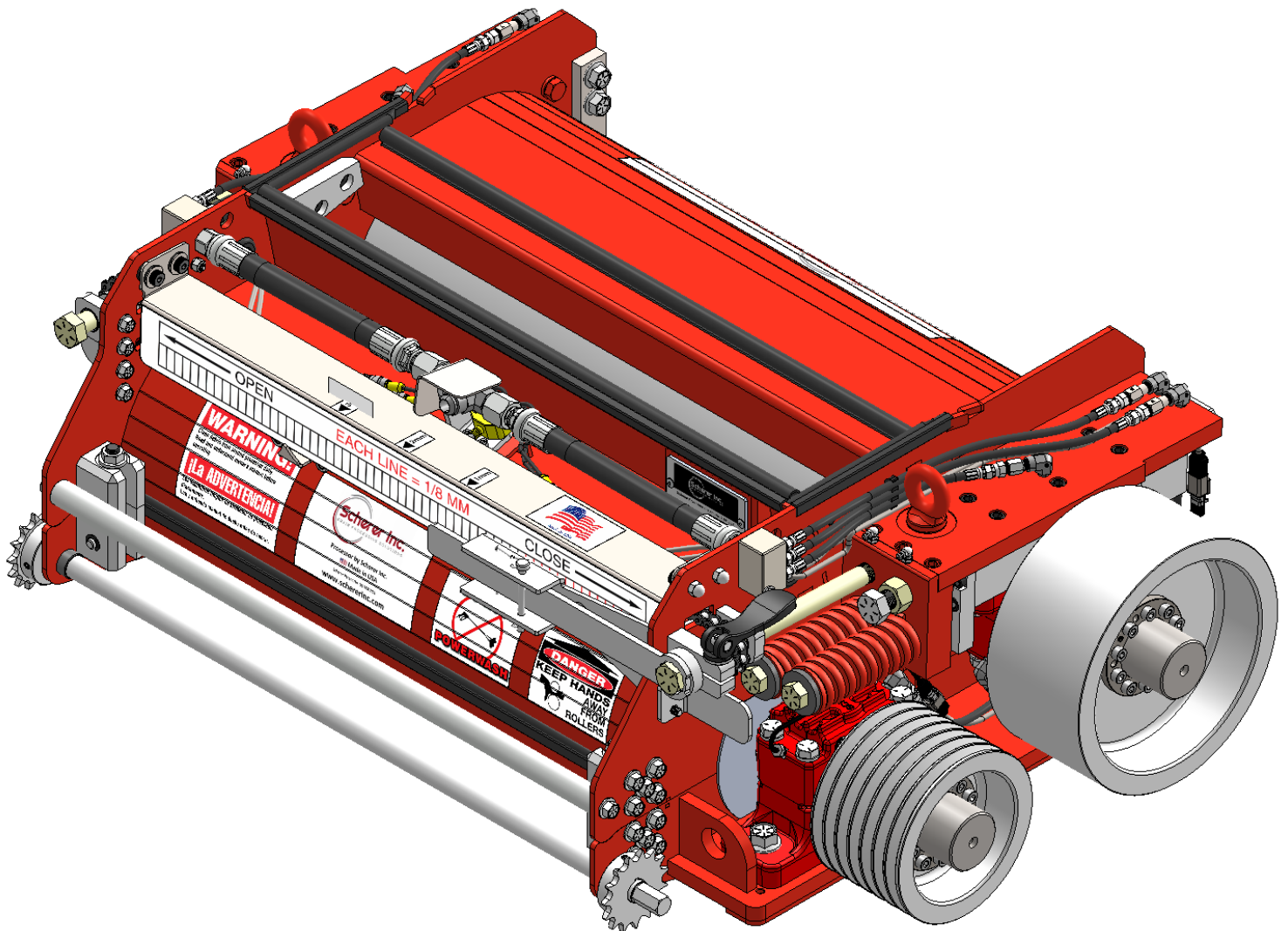

HIGH OUTPUT

Manual Part Number: MANHO2019
REV-A



46994 Mindy Street • Tea, SD 57064-8113 • 605-368-2659 • 800-883-9790 • www.scherercorrugating.com • FAX 605-368-9737

After hours: Jim (605) 940-6356, Jason (605) 941-3458, Lyndon (605) 941-0502

SCHERER PROCESSOR

Model: HO

U.S. Patent No. 7,681,384
Other Patents Applied For

**OPERATOR'S
AND PARTS MANUAL**

**SCHERER DESIGN
ENGINEERING, INC.**

1-800-883-9790

FOREIGN PATENTS APPLIED FOR
MANHO2019 (REV-A)

Index

<u>Section</u>	<u>Page #</u>
Introduction	1
Safety	2-3
Installation	4
Roll Gap Adjustment	5
LubriMist Maintenance	6
Warranty	7
Complete Assembly View	8
Processor Accessory Parts List	9
Bottom Section Diagram	10
Bottom Section Parts List	10A
Top Section Diagram	11
Top Section Parts List	11A
Top Section Parts List	11B
Top Section Diagram	12
Top Section Parts Assemblies	12A
Roller Diagram	13
Roller Parts List	13A
Lubrication System Diagram Claas 494,496, And 497	14
Lubrication System Parts List Claas 494,496, And 497	14A
Lubrication System Diagram Claas 498	15
Lubrication System Parts List Claas 498	15A
Pneumatic Tension Drive System Diagram	16
Pneumatic Tension Drive System Parts List	16A
Pneumatic Tension Drive System Parts List	16B
Pneumatic Tension Drive System Diagram	17
Pneumatic Part Assemblies	17A
Sentry System Parts ('494,'496,'497)	18-18A
Sentry System 2.0 Parts	18B-18C
'494 Pneumatic System Install	19-22
'496/'497 Pneumatic System Install	23-26
Pneumatic System Install ('498)	27-30
Sentry System 2.0 Install	31-34
Stone Door Bracket Install	35-36
Sentry System 2.0 Operation and Troubleshooting	37-39
7-Groove Drive Kit Install ('494,'496,'497)	40-41
Roll Change Instructions	42
Bearing Removal & Installation	43-46
Common Torque Specifications	47
Maintenance Intervals	48
END OF YEAR MAINTENANCE	49
Sentry Operational Guidelines ('494,'496,'497)	50
Sentry Troubleshooting ('494,'496,'497)	51
Sentry Installation ('494,'496,'497)	52-55
Sentry Operation Notes ('494,'496,'497)	56
LubriMist Installation ('494,'496,'497)	57-58
Taper Lock Install/Removal	59-60
Lubrimist Schematic	61

Introduction

We would like to take this opportunity to thank you and welcome you to the fine group of Scherer Processor owners. You have selected one of the many high quality and precision built processors that Scherer Design Engineering has to offer. Due to the success of the Scherer H.D. and H.P. Processors, we have developed and manufactured the Scherer HO Processor. Therefore, after years of designing and in-field success, Scherer Design Engineering is proud to offer the HO Processor.

This instruction manual contains specific operating, maintenance, and parts information to help you obtain the most satisfactory performance from your processor. This manual describes how to operate, maintain, and repair your processor.

Proper long-term performance of this equipment is possible only with the cooperation and attention of adequately trained operators and well informed maintenance personnel.

The factory carefully assembled, inspected and tested your processor. Before placing the processor into operation, please read the instruction manual carefully. Study the correct operating procedures and become familiar with the operating process and related machinery.

We are always trying to improve our product as much as possible. If you have any suggestions or concerns about how to make this processor better, feel free to give us a call at any time, your feedback is always welcomed.

The Scherer Design Engineering Team

Safety

Warning: Read and understand all of the following safety messages. Be familiar with general operating and maintenance instructions. Be sure to lock out the power supply before performing any maintenance and adjustments. The person performing the maintenance should be the only one with the ignition key for the cutter.

General Safety Practices,

Always observe safe operating practices around machinery. Most accidents are the result of carelessness or negligence. All rotating machinery is potentially dangerous. Guard and operate rotating machinery as required by applicable laws, regulations and good standard safety practices.

Before doing any maintenance on engine driven machinery, turn off ignition. Remember, the person doing the maintenance or adjustment should be the only one with the ignition key.

Use the proper tools for each maintenance task. Keep hoisting equipment in good condition and **DO NOT** stand under objects being hoisted. Keep a clean work area to ensure workers have good footing.

Inlet/Discharge Opening Hazard

The processor has an inlet and discharge opening. Injury will result if persons or objects fall into the inlet or discharge. A serious hazard exists if a person places their arm or any object into the inlet or discharge area of the processor. **DO NOT** remove protective guards.

Belt Drive Hazard

Be sure that the belt guards are in place before ever operating the processor.

Rotating Rolls Hazard

The rotating rolls are a severe hazard. The rolls turn at high speeds and operate with a grinding action that will pull objects between the rolls. Keep all body parts and all objects out of this area. **DO NOT** insert any part of your body or any tool into the roller area.

Eye Protection

Wear approved safety glasses when working around all equipment. Moving machinery can throw objects unexpectedly.

Head Protection

Wear an approved hard hat while installing the processor into and out of the machine. Falling objects or low overhead can cause serious injury.

Hearing Protection

Under normal operating conditions, this machine does not produce hazardous noise. However, the cutter itself is very noisy when operated at full throttle. Wear approved hearing protection as needed when working around equipment.

Installation

Before lifting the processor into place in the cutter, ensure that the latch blocks are snug, and hinge bolts are tight. Always use the certified lifting chains provided with the processor to lift the processor in and out of the cutter. Never stand under the processor when it is lifted overhead.

You can install the processor from the side or from the top. For ease of installation, remove the cross bar support that is bolted to the floor and to the discharge chute. Place processor in the cutter. If you have removed the cross bar support, please install it back into place at this time.

Slide the processor in the operating position, using the same clamping system that is in place for the original processor. Ensure the latch blocks on the processor are tight.

With the processor ahead and secured into the operating position, you now need to check proper pulley alignment. Do this by laying a straight edge along the main drive pulley and along the processor pulleys. If any adjustment needs to be done, please refer to keyless locking hub torque specifications in the back of this manual.

The roll gap was set at 4 mm and the scale has been marked at the 4 mm setting. Unless the gap has been changed, the roll adjustment should not have to be changed until some product has been run through it.

Install the provided oil mist system that came with your Scherer Processor. Finally, connect the oil mister to the processor, ensuring that the coupler is tight.

Roll Gap Adjustment

Once the processor is installed in the cutter and some product has been run through it, you may need to adjust the roll gap. To do this, you will use the adjustment tool provided. Loosen the adjustment clamp lever on right side adjustment bolt. Rotate the bolt clockwise to open the gap, and counter-clockwise to close the gap. Return the adjustment tool to its original position. **The adjustment tool is also a lock for the roll position.** You will not be able to adjust the rolls closer than 1 mm (.040) because of the factory setting of the roll stops (prevents the rolls from hitting). **The processor is not intended to be run with the slide blocks against the roll stops.** When adjusting, watch pointer move across scale. Use the scale to determine your roll gap. The Processor was set at the factory to 4mm. When the adjustment is complete, make sure that the adjustment clamp lever is hand tightened. After you have a number of hours on your processor you may need to adjust your rolls together to compensate for wear. After a number of adjustments, and the pointer moves onto or near the red marks on scale, the adjustment bolts may become free from tension. If you still need to close your roll gap further you may have to clean behind the bearing slide plates and adjust roll stop bolts to allow for more movement.

LubriMist Maintenance



- Make sure to maintain an air pressure of 35psi at the LubriMist regulator.
- Oil fill is the plug located on the front of the LubriMist reservoir.
- Fill with oil until the oil level matches the full mark on the sight glass. **DO NOT OVERFILL!! LUBRIMIST WILL NOT FUNCTION PROPERLY IF IT IS FILLED ABOVE THE FULL MARK!!**
- We use Chevron Cetus Hypersyn. It is an ISO 32 100% synthetic oil (equivalent to SAE 10 weight). This is called turbine oil by some manufacturers. It is available from Scherer Design in gallon and 5 gallon quantities.
- In very wet corn conditions, we recommend changing the oil in the bearings every two weeks and at the end of the season. To change the oil, remove the most convenient plug and drain. Refill the bearing housing with 3 oz. of fresh oil.
- **At the end of season, remove all water from regulator and air lines to prevent damage from freezing.**
- When removing the kernel processor, disconnect the braided steel hose from the LubriMist exhaust port and plug the end of the hose to keep dirt out. Also cap off the LubriMist exhaust port and turn off the air supply to the LubriMist.
- **THE LUBRIMIST SYSTEM SHOULD NOT BE PRESSURIZED IF THE EXHAUST PORT IS CAPPED OFF.**

LIMITED WARRANTY FOR SCHERER HO KERNEL PROCESSOR

IT IS EXPRESSLY AGREED THAT THE FOLLOWING WARRANTY IS GIVEN BY SCHERER DESIGN ENGINEERING, INC. IN LIEU OF ALL OTHER WARRANTIES, WHETHER EXPRESS, IMPLIED OR STATUTORY, **INCLUDING THOSE OF MERCHANTABILITY AND FITNESS FOR A PARTICULAR PURPOSE**, AND OF ANY OTHER OBLIGATION OR LIABILITY ON OUR PART OF ANY KIND OR NATURE WHATSOEVER.

No representative of ours has any authority to waive, alter, vary or add to the terms hereof without prior approval in writing, to our customer, signed by an officer of our company. It is expressly agreed that the entire warranty given to the customer is embodied in this writing; that this writing constitutes the final expression of the parties' agreement with respect to warranties; and that it is a complete and exclusive statement of the terms of the warranty.

We warrant to our customers that all products manufactured by us will be free from any manufacturing defects at the time of shipment to our customer for a period of one (1) year from the date of shipment. All warranty claims must be submitted to us within ten days of discovery of defects within the warranty period, or shall be deemed waived. As to our products that are proven to have been defective at the time of shipment, and that were not damaged in shipment, the sole and exclusive remedy shall be repair or replacement of the defective parts or repayment of the proportionate purchase price for such products or parts, at our option. Replacement parts shall be shipped free of charge f.o.b. from our factory. This constitutes a full and complete statement of the warranty provided and the product is otherwise deemed to have been accepted AS IS and with all faults.

This warranty shall not apply to any product which has been subject to operator misuse; misapplication, neglect (including but not limited to improper maintenance and storage); accident; improper installation, modification (including but not limited to use of unauthorized parts or attachments), adjustment, repair or lubrication. Misuse also includes, without implied limitation, deterioration in the product or part caused by chemical action, wear caused by the presence of abrasive materials, improper lubrication, and failure to clean the processor area daily and to follow the lubrication instructions which are provided. Identifiable items manufactured by others but installed in or affixed to our product are not warranted by us but, bear only those warranties, express or implied, given by the manufacturer of that item, if any.

Responsibility for proper use, installation, and application of the Scherer HO Kernel Processor rests solely with customer and it is expressly agreed between the parties that our liability for any damages arising out of or related to this transaction, or the use of our product, whether in contract, tort, or based upon any state or federal claim whatsoever, is exclusively limited to the repair or replacement of the product, or the parts thereof by us, or to a refund of the proportionate purchase price. We will not be liable for any other injury, loss, damage or expense, whether direct or consequential, including but not limited to loss of use, income, profit, production, or increased costs of operation, or spoilage of or damage to material, arising in connection with the sale, installation, use of, inability to use, or the replacement of, or late delivery of, our product.

It is also expressly agreed that any cause of action for breach of any warranty must be brought within one year from the date of the breach. Nothing contained herein shall be deemed to abrogate any legal rights or defenses the Producer may have relative to this product.

SCHERER PROCESSOR WITH ACCESSORIES

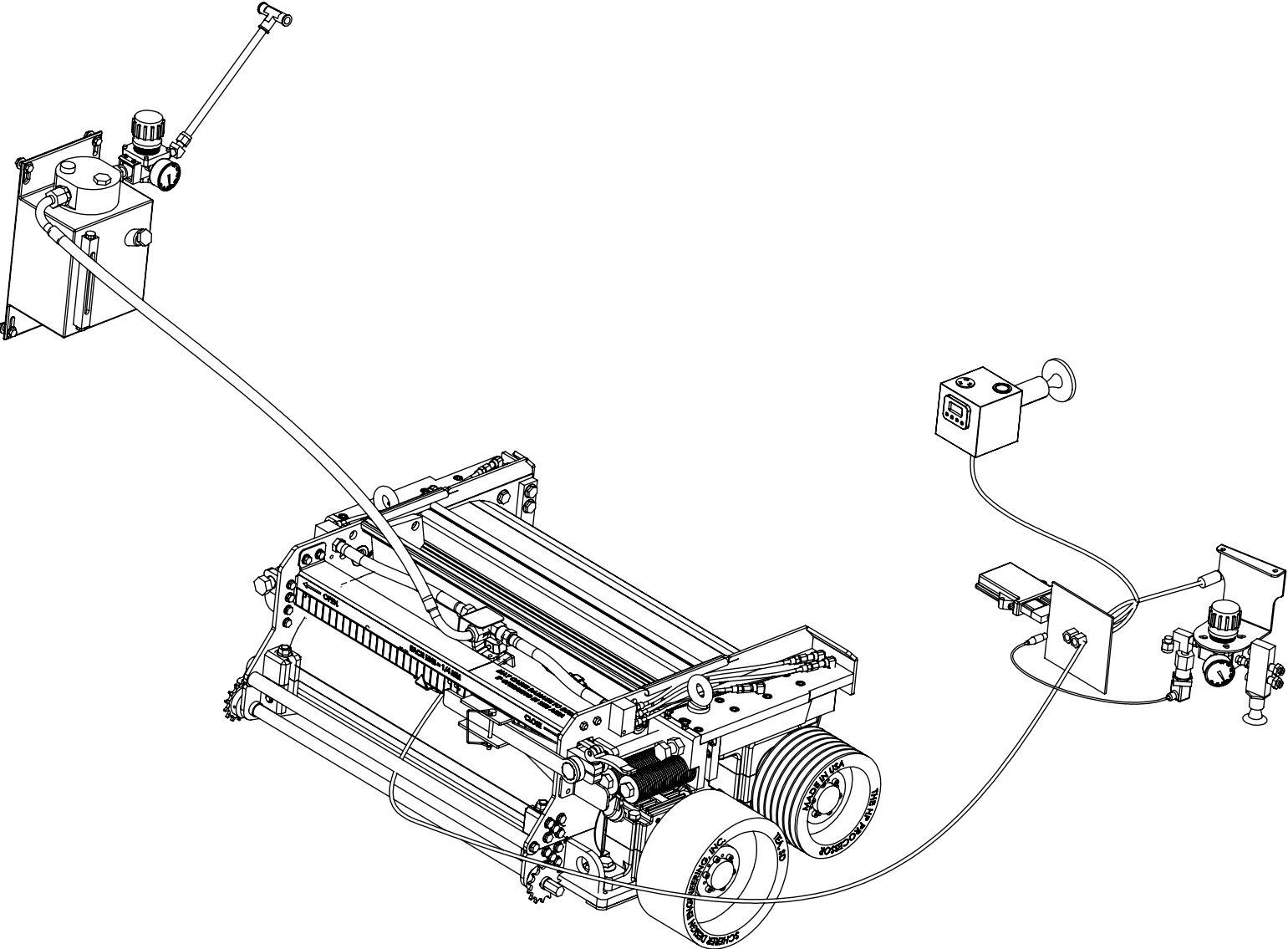

Processor Accessory Parts

A0001	H.D. Bearing Installation and Removal Tool
A0002	H.D. Bearing Removal Driver
A0003	Lift Chain
A0006	1 Gal. Chevron Cetus HyperSyn Oil
A0006.5	5 Gal. Chevron Cetus HyperSyn Oil
A0007	H.D. Track Extension
A0008	Laser Temp. Gun
A0010	H.P. Bearing Removal Tool
A0011	Laser Alignment Tool
A0015-1	Scherer Processor Brochure
A0015-2	HDS Owner's Manual
A0015-3	HP Owner's Manual
A0015-4	HPS Owner's Manual
A0015-5	HPM Owner's Manual
A0015-6	HPMS Owner's Manual
A0017	Dealer Pricing SD Card
A0019	Flash Drive
A0021	SKF Bearing Heater
A0022	Bearing Puller for the 60mm Shaft

SCHERER HO BOTTOM SECTION PARTS

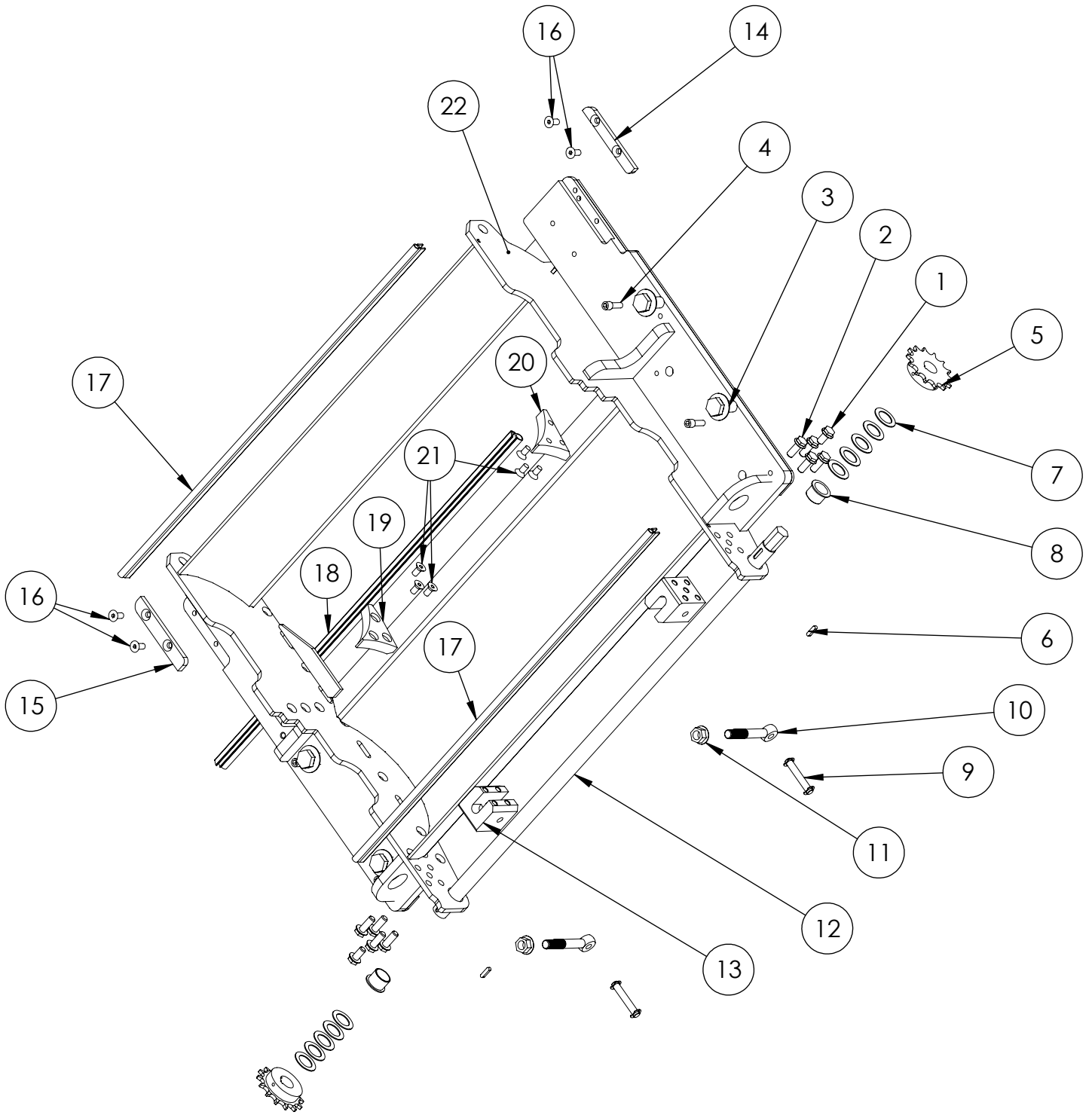

SCHERER HO BOTTOM SECTION PARTS LIST

	Part #	Qty.	Description
1	HPST1034.1	2	3/4" Latch Block Bolt
2	HPST1034	8	1" Latch Block Bolt
3	HPTB1010	4	.625 x 1.5 Bearing Housing Bolt
4	TB1008	4	.3125 x 1 Bearing Housing Bolt
5	B1027 B1027-15	2	Position Rod Sprocket Position Rod Sprocket ('498)
6	B1016	2	Key
7	B1029	10	Position Rod Washer
8	B1030	2	Position Rod Bushing
9	B1036	2	Latch Block Pin with Clips
10	B1037	2	Latch Block Eye Bolt
11	B1038	2	Latch Block Eye Bolt Nut
12	B1039	1	Position Rod
13	HPSB1035	2	Lower Latch Block
14	HPMB1040	1	Right Base Plate Adapter
15	HPMB1041	1	Left Base Plate Adapter
16	HPT1065	4	5/16-24 x 5/8 Flat Head
17	TB1043	2	Shroud Seal
18	T1054	1	.625 90° Bulb Seal
19	HOB1100	1	Bottom Left Cheek Plate
20	HOB1101	1	Bottom Right Cheek Plate
21	HPT1065	6	Cheek Plate Bolt
22	HOF1000.1	1	Bottom Frame Member

SCHERER HO TOP SECTION PARTS

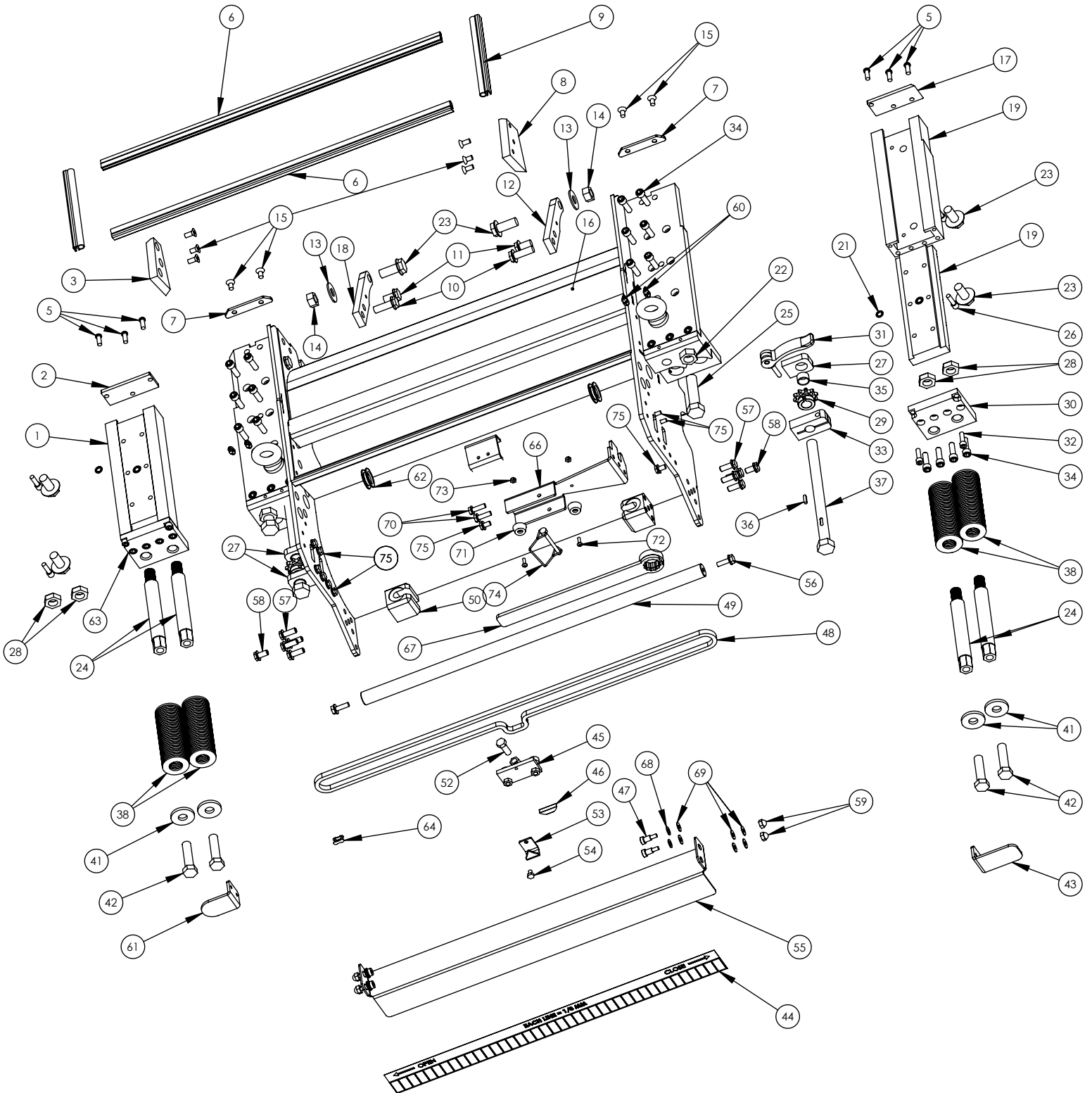

SCHERER HO TOP SECTION PARTS LIST

	PART #	QTY.	DESCRIPTION
1	HOT1100LA	1	Left Slide Assembly
2	HPT1002	1	Left Bearing Slide Front Cap
3	HOT1004	1	Left Cheek Plate
5	HPT1005	6	Slide Assembly Front Cap Bolt
6	T1054	2	5/8" 90° Bulb Seal
7	HDST1062	2	End Cap
8	HOT1003	1	Right Cheek Plate
9	HPT1010	2	90° Bulb Seal
10	HPST1011.2	2	1/2" x 1 1/2" Hinge Bolt
11	HPST1011.1	2	1/2" X 7/8" Hinge Bolt
12	HPST1012R	1	Right Hinge
13	HPST1013	2	Hinge Washer
14	HPST1014	2	Hinge Nut
15	HPT1065	10	5/8" Cheek Plate Bolt
16	HOF1000.2	1	Top Frame Member
17	HPT1017	1	Right Bearing Slide Front Cap
18	HPST1012L	1	Left Hinge
19	HOT1102RA	1	Right Slide Assembly
21	HPMT1105	2	Inner Bearing Slide O-Ring
22	HPST1025.1	2	Roll Dead Stop Nut
23	HPTB1010	6	5/8" x 1 1/2" Bearing Housing Bolt
24	HPST1003S	4	Short Spring Rod
25	HPST1025	2	Dead Stop Bolt
26	TB1008	4	5/16" x 1" Bearing Housing Bolt
27	HPT1027	3	Adjustment Bolt Guide
28	HPST1009	4	Spring Rod Lock Nut
29	B1067	2	Plated Sprocket
30	HPST1030	1	Right Bearing Slide Rear Cap
31	HPT1031	1	Adjustment Bolt Clamp Handle
32	B1024	4	5/16" x 1" SHCS
33	HPT1033	1	Adjustment Bolt Clamp
34	B1023	20	3/8" x 1 1/8" SHCS
35	HPT1035	3	Adjustment Bolt Bushing
36	B1016	2	Key
37	HOT1037	2	Adjustment Bolt
38	HPST1039	4	Springs
41	B1002	4	Spring Bolt Washer
42	B1001	4	Spring Bolt
43	HPT1113	1	Right Spring Guard

SCHERER HO TOP SECTION PARTS LIST

	PART #	QTY.	DESCRIPTION
44	HPST1056	1	Roll Gap Reference Sticker
45	B1061	1	Chain Tension Bracket
46	B1060	1	Chain Tension Key
47	HPT1117	4	5/16" Shoulder Bolt
48	HPT1048	1	Roll Gap Adjustment Chain
49	HPST1049	1	Lifting Rod
50	HPST1057	2	Top Latch Block
52	B1064	1	7/16" x 1 1/4" Bolt
53	B1053	1	Roll Adjustment Pointer
54	B1065	1	1/4" x 3/8" Pointer Bolt
55	HPT1055	1	Chain Guard
56	T1058	2	Lifting Rod Bolt
57	HPST1034	8	1" Latch Block Bolt
58	HPST1034.1	2	5/8" Latch Block Bolt
59	HPT1116	4	Acorn Nut
60	HPT1059	4	Grease Zerk
61	HPT1060	1	Left Spring Guard
62	HPT1106	2	Rubber Grommet
63	HPST1063	1	Left Bearing Slide Rear Cap
64	B1076	1	Chain Connector Link
66	HPT1097	1	Adjustment Wrench Holder
67	HPT1098	1	Adjustment Wrench
68	HPT1115	4	SS Washer
69	HPT1069	12	Rubber Washer
70	TB1034	2	1" Flange Bolt
71	HPT1107	2	Adjustment Wrench Bumper
72	HPT1108	2	Bumper Bolt
73	HPT1109	2	Bumper Bolt Acorn Nut
74	HPT1099	1	Adjustment Wrench Pin
75	HPT1051	10	Guide Bolt

SCHERER HO TOP SECTION PARTS

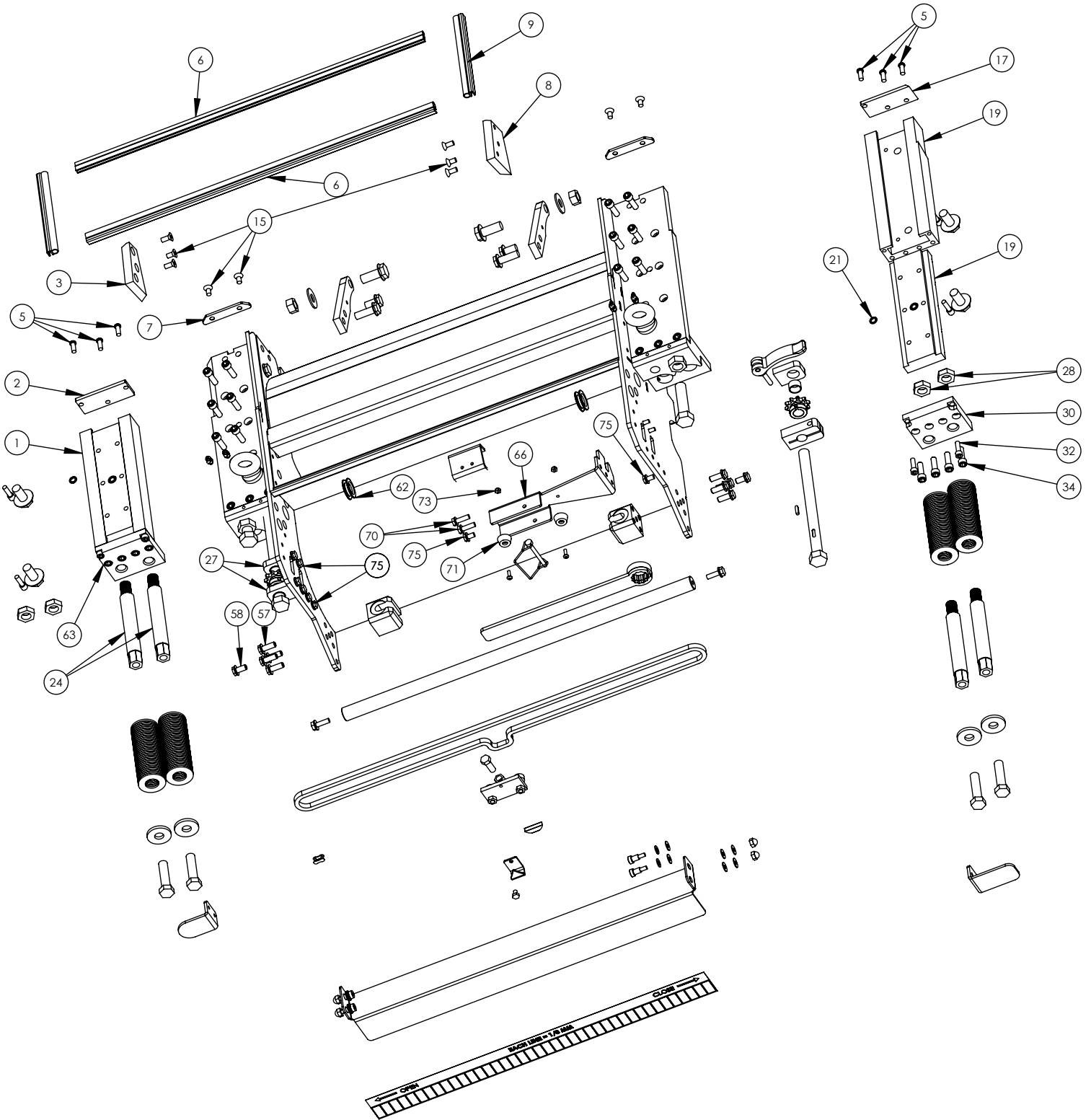

SCHERER HO TOP SECTION PARTS ASSEMBLIES

	PART #	QTY.	DESCRIPTION
*	HOT1103	1	Complete Left Side Bearing Assembly
HOT1103 INCLUDES THE FOLLOWING PARTS			
1	HOT1100LA	1	Left Slide Assembly
2	HPT1002	1	Left Bearing Slide Front Cap
5	HPT1005	3	Slide Assembly Front Cap Bolt
20	HPT1104	1	Inner Bearing Slide
21	HPMT1105	1	Inner Bearing Slide O-Ring
32	B1024	2	5/16" x 1" SHCS
34	B1023	4	3/8" x 1 1/8" SHCS
63	HPST1063	1	Left Bearing Slide Rear Cap
*	HOT1104	1	Complete Right Bearing Slide Assembly
HOT1104 INCLUDES THE FOLLOWING PARTS			
5	HPT1105	3	Slide Assembly Front Cap Bolt
34	B1023	4	3/8" x 1 1/8" SHCS
32	B1024	2	5/16" x 1" SHCS
30	HPST1030	1	Right Bearing Slide Rear Cap
19	HOT1102RA	1	Right Slide Assembly
21	HPMT1105	1	Inner Bearing Slide O-Ring
17	HPT1017	1	Right Bearing Slide Front Cap
*	HOT1039RL	1	Cheek Plate Kit
HOT1039RL INCLUDES THE FOLLOWING PARTS			
3	HOT1004	1	Left Cheek Plate
15	HPT1065	12	5/8" Cheek Plate Bolt
8	HOT1003	1	Right Cheek Plate
19(Pg.10)	HOB1100	1	Left Bottom Cheek Plate
20(Pg.10)	HOB1101	1	Right Bottom Cheek Plate
*	HPMTB1075	1	Bulb Seal Kit
HPMTB1075 INCLUDES THE FOLLOWING PARTS			
6	T1054	2	5/8" 90° Bulb Seal
9	HPT1010	2	90° Bulb Seal
	TB1043	2	Shroud Seal
TB1043 SEALS BETWEEN THE TOP AND BOTTOM FRAME HALVES			

SCHERER HO ROLLER PARTS

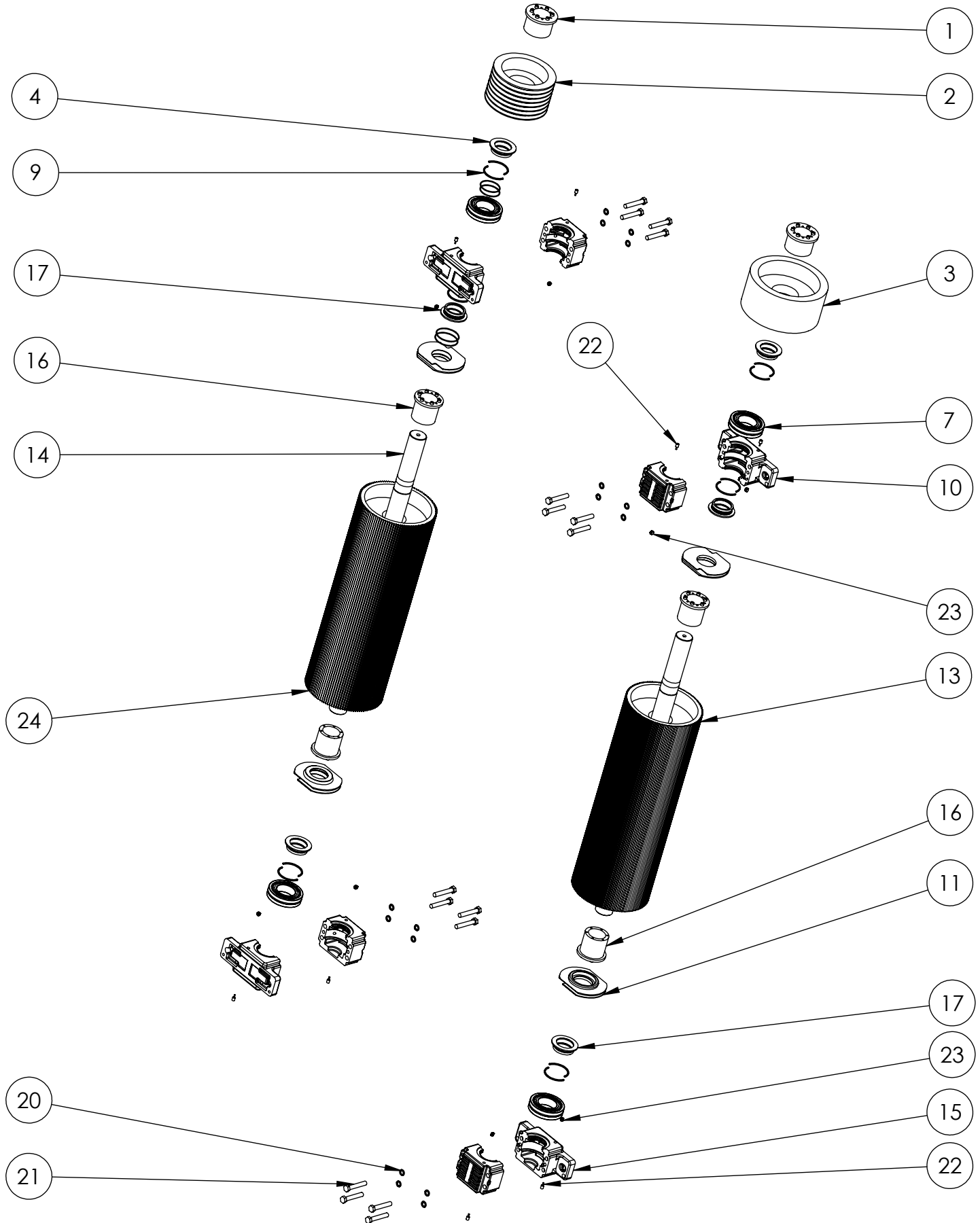

SCHERER HO ROLL PARTS LIST

	Part #	Qty.	Description
1	HOR1001	2	Pulley Locking Hub
2	HOR1002-175	1	175mm Grooved Pulley
3	HOR1003-260	1	260mm Smooth Pulley
4	HOR1004-60	2	Outside Housing Seal
7	HOR1007	4	Roller Bearing
9	HPR1009	12	Fiber Oil Seal
10	HOR1010	2	Drive Side Bearing Housing
11	JDRM1011	4	Spool Seal Assembly
13	HOR60-160	1	Standard Roll with Shaft (160 groove)
13	HOLCR60-160	1	Long Chop Roll with Shaft (160 groove)
14	HOR1014	2	Roll Shaft
15	HOR1015	2	Idle Side Bearing Housing
16	HOR1016	2	Roll to Shaft Locking Hub
17	HOR1004-70	4	Inside Housing Seal
20	R1231	16	Bearing Housing Lock Washer
21	R1230	16	Bearing Housing Bolt
22	R1236	8	Magnetic Drain Plug
23	R1235	16	Drain Plug
24	HOR60-120	1	Standard Roll with Shaft (120 groove)
24	HOLCR60-120	1	Long Chop Roll with Shaft (120 groove)
*	HOR60-120-C	1	Standard Roll with Shaft, Bearings, Seals, & Bearing Housings (120 groove)
*	HOR60-160-C	1	Standard Roll with Shaft, Bearings, Seals, & Bearing Housings (160 groove)
*	HOLCR60-120-C	1	Long Chop Roll with Shaft, Bearings, Seals, & Bearing Housings (120 groove)
*	HOLCR60-160-C	1	Long Chop Roll with Shaft, Bearings, Seals, & Bearing Housings (160 groove)
*	HOR60-120-C-NH	1	Standard Roll with Shaft, Bearings, Seals, *NO Bearing Housings (120 groove)
*	HOR60-160-C-NH	1	Standard Roll with Shaft, Bearings, Seals, *NO Bearing Housings (160 groove)
*	HOLCR60-120-C-NH	1	Long Chop Roll with Shaft, Bearings, Seals, *NO Bearing Housings (120 groove)
*	HOLCR60-160-C-NH	1	Long Chop Roll with Shaft, Bearings, Seals, *NO Bearing Housings (160 groove)
**	A0022	1	Bearing Puller

SCHERER HO PROCESSOR LUBRICATION SYSTEM PARTS CLAAS 494,496, AND 497

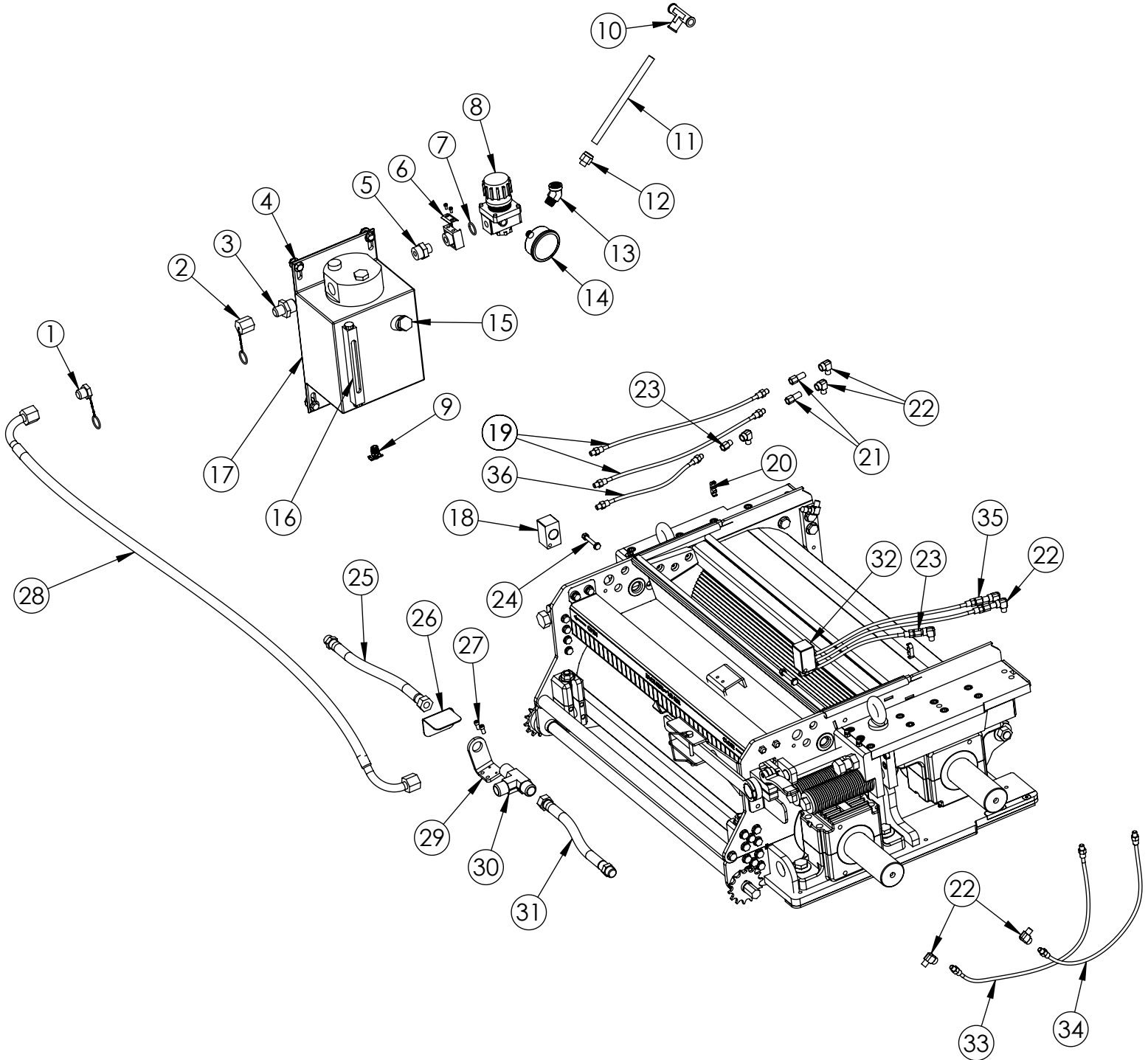

SCHERER HO PROCESSOR LUBRICATION SYSTEM PARTS LIST CLAAS 494,496, AND 497

	Part #	QTY.	Description
1	OM-1005	1	Flared Plug
2	OM-1006	1	Flared Cap
3	OM-1008	1	Reducing Fitting
4	HPT-1092	4	Oil Mister Mounting Hardware
5	OM-1022	1	3/4" to 1/2" Reducing Fitting
6	OM-1020	1	Regulator Attachment
7	OM-1020.1	1	Regulator Attachment O-ring
8	OM-1023	1	Air Regulator
9	OM1039	1	Stop Cock Drain
10	HPD-1349	1	12-mm Push-Loc Tee
11	OM-1014	1	Air Supply Line
12	OM-1025	1	12mm Push-Loc x 3/8" male
13	OM-1017	1	45 degree fitting
14	OM-1015	1	Regulator Gauge
15	OM-1016	1	Oil Fill Plug
16	OM-1012	1	Sight Glass
17	OM-1000	1	Oil Mist Generator
18	HPT-1080	1	Left Oil Mist Manifold
19	HPG1153	4	17 7/8" Lubrication Line
20	G-1111	2	Lubrication Line Clip
21	OM-1001L	2	Left Misting Reclassifier
22	HPT-1085	10	1/8" NPT Street Elbow
23	OM-1002	2	Condensing Reclassifier
24	HPT-1091	2	Manifold Mounting Hardware
25	HPG-1121	1	Left Oil Mist Hose
26	HPT-1087	1	Stainless Bulkhead Guard
27	HPT-1093	2	Tee Bracket Mountig Bolt
28	HPG-1123	1	Main Oil Supply Hose('496,'497)
29	HPT-1090	1	Tee Bulkhead Mounting Bracket
30	HPT-1082	1	Bulkhead Tee
31	HPG-1120	1	Right Oil Mist Hose
32	HPT-1081	1	Right Oil Mist Manifold
33	HPG1154	2	23 1/2" Lubrication Line
34	HPG-1110	2	16 3/4" Lubrication Line
35	OM-1001R	2	Right Mist Reclassifier
36	HPG1152	2	11 5/8" Lubrication Line
37	OM-1026	1	Gasket Kit

SCHERER HO PROCESSOR LUBRICATION SYSTEM PARTS CLAAS 498

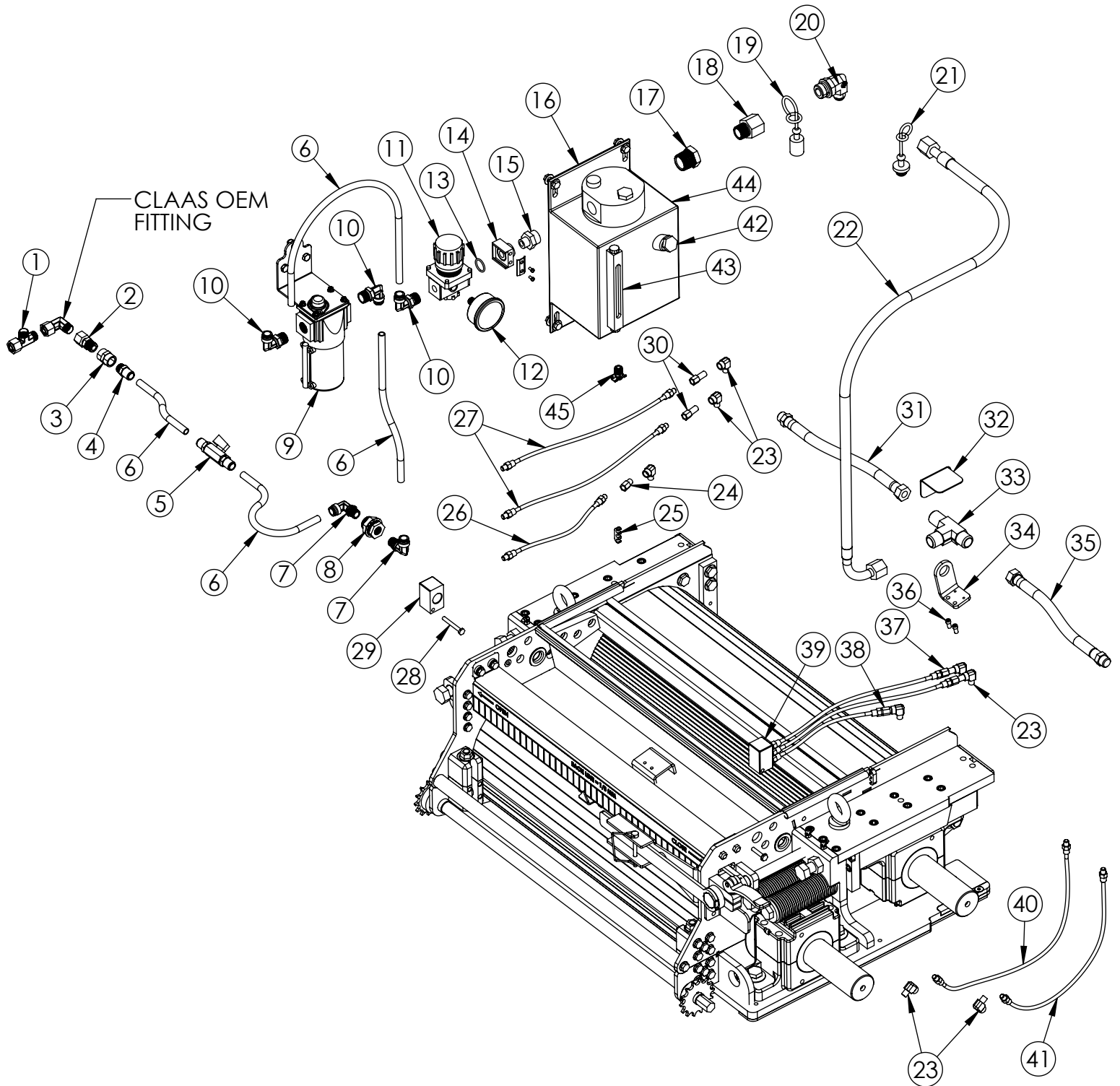

SCHERER HO PROCESSOR LUBRICATION SYSTEM PARTS LIST CLAAS 498

Item #	Part #	QTY.	Description
1	HPD1424	1	"T" Fitting
2	HPD1423	1	Conversion Fitting
3	HPD1422	1	Union
4	OM1025	1	Pushlock Fitting
5	HPD1359	1	1/4 Turn Valve
6	NYLONTB12MM	1	Air Supply Line
7	HPD1420	2	90° Swivel Fitting
8	HPD1425	1	Bulkhead Fitting
9	HPD1427	1	Coalescing Filter Assembly
10	OM1033	3	90° Fitting
11	OM1032	1	Air Regulator
12	OM1015	1	Regulator Guage
13	OM1020.1	1	Regulator Attachment O-ring
14	OM1020	1	Regulator Attachment
15	OM1022	1	Reducing Fitting
16	HPT1092	4	Oil Mister Mounting Hardware
17	OM1003	1	Reducing Bushing
18	OM1030	1	Reducing Fitting
19	SPL10030	1	Rubber Cap
20	OM1031	1	90° Fitting
21	SPL10031	1	Rubber Plug
22	OM1038	1	Main Oil Supply Hose ('498)
23	HPT1085	10	Street Elbow
24	OM1002	2	Condensing Reclassifier
25	G-1111	2	Lubrication Line Clip
26	HPG1152	2	11-5/8" Lubrication Line
27	HPG1153	4	17-7/8" Lubrication Line
28	HPT1091	2	Manifold Mounting Hardware
29	HPT1080	1	Left Oil Mist Manifold
30	OM1001L	2	Left Misting Reclassifier
31	HPG1121	1	Left Oil Mist Hose
32	HPT1087	1	Stainless Bulkhead Guard
33	HPT1082	1	Bulkhead Tee
34	HPT1090	1	Tee Bulhead Mounting Bracket
35	HPG1120	1	Right Oil Mist Hose
36	HPT1093	2	Tee Bracket Mounting Bolt
37	OM1001R	1	Right Mist Reclassifier
38	OM1002	2	Condensing Reclssifier
39	HPT1081	1	Right Oil Mist Manifold
40	HPG1154	2	23-1/2" Lubrication Line
41	HPG1110	2	16-3/4" Lubrication Line
42	OM1016	1	Oil Fill Plug
43	OM1012	1	Sight Glass
44	OM1000	1	Oil Mist Generator
45	OM1039	1	Stop Cock Drain

SCHERER HO PROCESSOR PNEUMATIC TENSION 7-GROOVE DRIVE SYSTEM PARTS

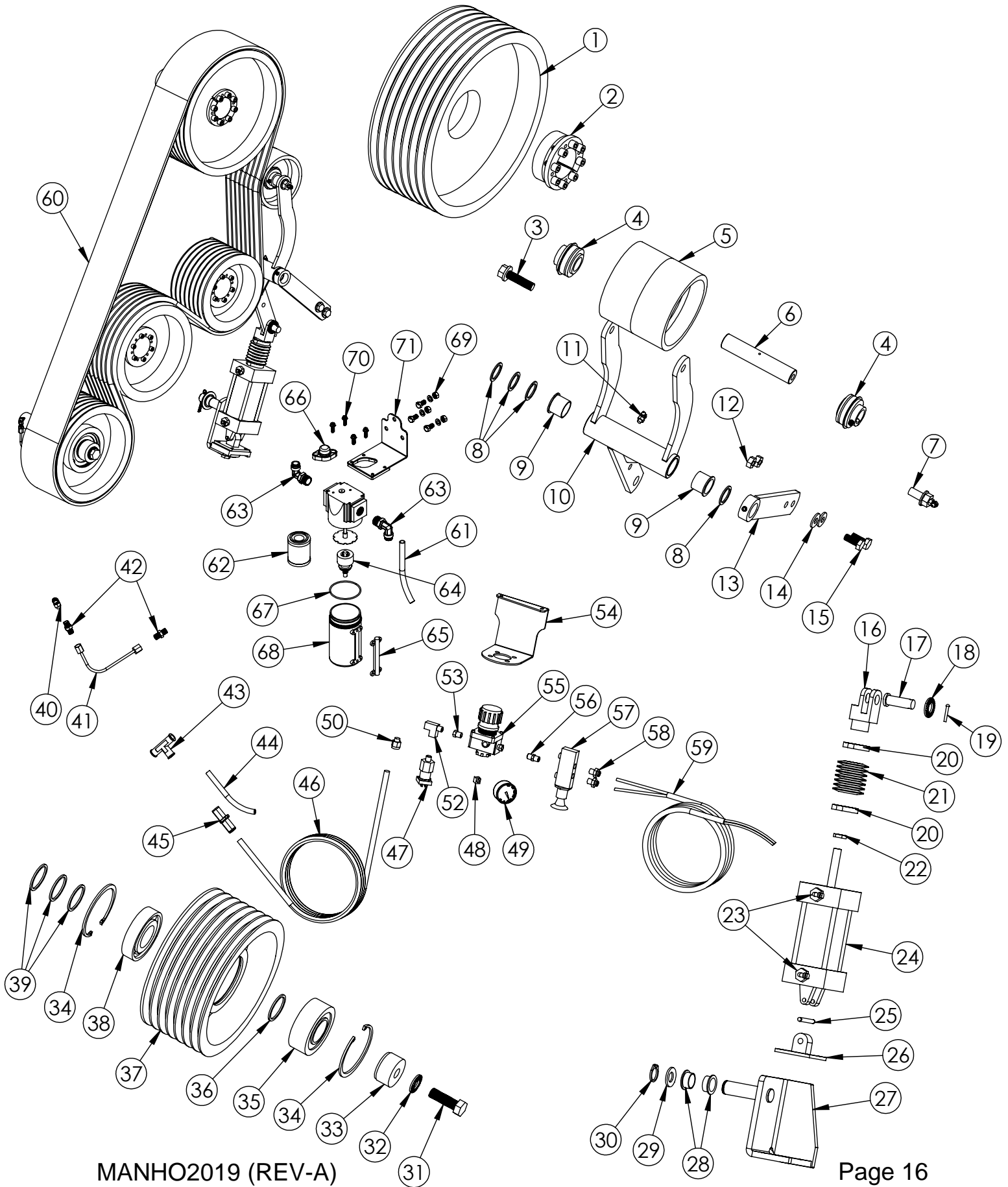

SCHERER HO PROCESSOR PNEUMATIC TENSION DRIVE PARTS LIST

	PART #	QTY.	DESCRIPTION
1	HOD1301 D1301-7 HPD1301-7.45	1	7 Groove Pulley (60mm shaft) 7 Groove pulley (55mm shaft) 7 groove pulley (45mm shaft)
2	HOD1302 D1302-7 D1302	1	60mm Locking Hub with Bolts 55mm Locking Hub with Bolts 45mm Locking Hub with Bolts
3	D1303	1	1/2 x 1" Bolt
4	D1304	2	ER16 Bearing
5	D1305-7	1	Tension Pulley (For 7 Groove Belt)
6	D1308-7	1	Tension Pulley Shaft for 7 Groove
7	D1309	1	1/2 x 1" Bolt with Grease Fitting
8	D1312	4	Tension Arm Washers
9	D1310	2	Tension Arm Bushings
10	HPD1307-7	1	Tensioner Arm for 7 Groove
11	D1313	1	Tensioner Arm Grease Zerk
12	HPD1375	2	M10 Nut
13	HPD1373	1	Pivot Tube Brace
14	HPD1376	2	10mm Washer
15	HPD1374	2	M10 x 30 Bolt
16	HPD1353-7	1	Pneumatic Cylinder Fork for 7 Groove
17	HPD1314-7	1	5/8 x 1 3/4" Clevis Pin
18	D1316-7	1	Clevis Pin Washer
19	D1315	1	Clevis Pin Cotter Key
20	HPD1399	2	Bellow Clips
21	HPD1396	1	Bellow
22	HPD1391	1	1/2-20 Jam Nut
23	HPD1354	2	3/8" Swivel Fitting
24	HPD1341	1	4" Pneumatic Tension Cylinder
25	HPD1343	1	Pneumatic Cylinder Pin with Snap Rings
26	HPD1344	1	Pneumatic Cylinder Male Clevis
27	HPD1346-7	1	Pneumatic Tension Arm Bracket
28	D1323	2	Bracket Bushings
29	D1324	1	Bracket Shaft Washer
30	D1325-7	1	Bracket Shaft Snap Ring
31	D1326	1	16 x 45mm Bolt
32	D1327	1	16mm Washer

SCHERER HO PROCESSOR PNEUMATIC TENSION DRIVE PARTS LIST

	PART #	QTY.	DESCRIPTION
33	D1338-7	1	Idler Shaft Cap for 7 Groove
34	D1329-7	2	Idler Pulley Snap Ring
35	D1333-7	1	5308 Bearing
36	D1331-7	1	Notched Spacing Washer for 7 Groove
37	D1332-7	1	Idler Pulley (For 7 GrooveBelt)
38	D1330-7	1	6308 Bearing
39	D1334-7	3	Hardened Spacer Rings
40	D1338	1	Grease Fitting
41	HOD1337	1	Grease Tube W/Fittings {Includes 42} ('496,'497)
42	D1336	2	Grease Tube Male Adapter
43	HPD1349	1	12mm "T" Fitting
44	HPD1361	1	Short 12mm Hose
45	HPD1359	1	12mm Valve Assembly
46	HPD1348	1	H.P.12mm Air Hose (12 ft)
47	HPD1370	1	Air Pressure Sensor
48	OM1024	1	135 Degree Elbow
49	OM1015	1	Air Pressure Gauge
50	HPD1358	1	1/4" - 12mm Fitting
51	HPD1402	1	90 Degree Fitting
52	HPD1371	1	Air Pressure Sensor Tee
53	OM1021	2	1/2 to 3/8" Reducing Fitting
54	HPD1403	1	Air Regulator Bracket
55	OM1023	1	Air Pressure Regulator
56	HPD1408	1	3/8" Fitting
57	HPD1407	1	Air Actuator
58	HPD1406	2	3/8 to 1/4" Push-Loc Fitting
59	HPD1352	1	H.P. 1/4" Air Hose Assembly
60	HOD1435-7 HOD1436-7	1	Standard 7 Groove Drive Belt (11" KP) "S" Drive 7 Groove Belt (11" KP)
61	HPD1419	1	12mm Air Cleaner Hose
62	HPD1411.1	1	Replacement Filter Element
63	HPD1411.3	2	90° Swivel Push Lock Fitting
64	HPD1411.4	1	Auto Drain Float
65	HPD1411.5	1	Sight Glass
66	HPD1411.6	1	Pop-Up Indicator
67	HPD1411.7	1	Air Cleaner Bowl O-Ring
68	HPD1411.8	1	Air Cleaner Bowl
69	HPD1411.9	1	Mntg Hardware Bolts/Nuts/Washers
70	HDP1411.10	1	Mntg Brkt/Air Cleaner - Bolts
71	HPD1414	1	Air Filter Mounting Bracket

SCHERER HO PNEUMATIC ASSEMBLIES

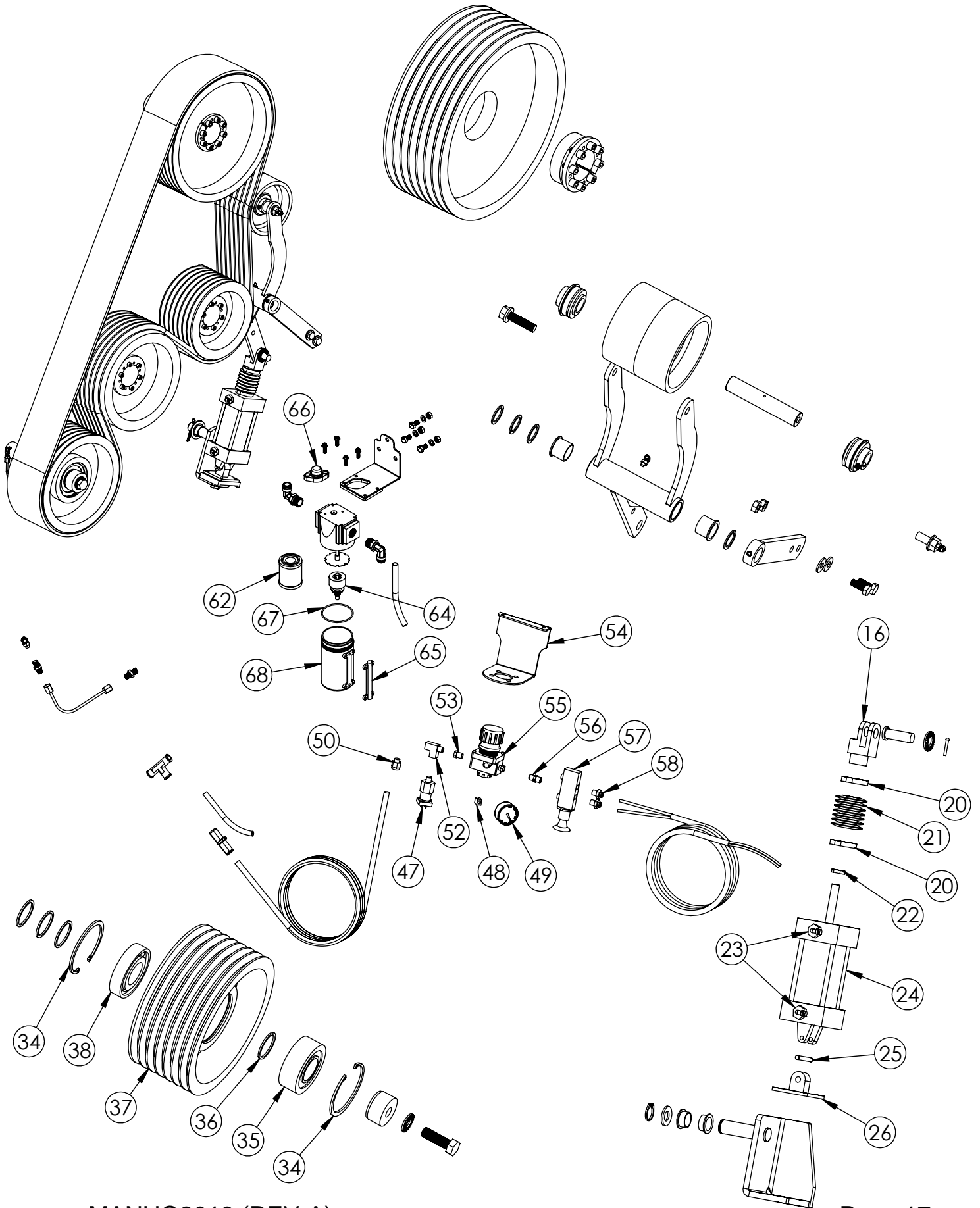

SCHERER HO PNEUMATIC ASSEMBLIES

	PART #	QTY.	DESCRIPTION
*	HPD1300-60	1	Complete 60mm Drive Kit '496 (880); '497 (960, 970, 980)
*	HPD1300-55	1	Complete 55mm Drive Kit '497 (930, 940, 950)
*	HPD1300-45	1	Complete 45mm Drive Kit '496 (840, 850, 860)
*	HPD1398-7	1	Complete 4" Penumatic Cylinder
HPD1398-7 INCLUDES THE FOLLOWING PARTS			
16	HPD1353-7	1	Pneumatic Cylinder Fork for 7 Groove
20	HPD1399	2	Bellow Clips
21	HPD1396	1	Bellow
22	HPD1391	1	1/2-20 Jam Nut
23	HPD1354	2	3/8" Swivel Fitting
24	HPD1341	1	4" Pneumatic Tension Cylinder
25	HPD1343	1	Pneumatic Cylinder Pin with Snap Rings
26	HPD1344	1	Pneumatic Cylinder Male Clevis
*	HPD1410-7	1	Complete 7 Groove Idle Pulley
HPD1410-7 INCLUDES THE FOLLOWING PARTS			
34	D1329-7	2	Idle Pulley Snap Ring
35	D1333-7	1	5308 Bearing
36	D1331-7	1	Notched Spacing Washer for 7 Groove
37	D1332-7	1	Idler Pulley (For 7 GrooveBelt)
38	D1330-7	1	6308 Bearing
*	HPD1385	1	'494 Pressure Regulator and Actuator Assembly
HPD1385 INCLUDES THE FOLLOWING PARTS			
47	HPD1370	1	Air Pressure Sensor
48	OM1024	1	135 Degree Elbow
49	OM1015	1	Air Pressure Gauge
50	HPD1358	1	1/4" - 12mm Fitting
52	HPD1371	1	Air Pressure Sensor Tee
53	OM1021	2	1/2 to 3/8" Reducing Fitting
54	HPD1403	1	Air Regulator Bracket
55	OM1023	1	Air Pressure Regulator
56	HPD1408	1	3/8" Fitting
57	HPD1407	1	Air Actuator
58	HPD1406	2	3/8 TO 1/4" Push-Loc Fitting
*	HPD1411	1	Colesant Filter Assembly
HPD1411 INCLUDES THE FOLLOWING PARTS			
62	HPD1411.1	1	Replacement Filter Element
64	HPD1411.4	1	Auto Drain Float
65	HPD1411.5	1	Sight Glass
66	HPD1411.6	1	Pop-Up Indicator
67	HPD1411.7	1	Air Cleaner Bowl O-Ring
68	HPD1411.8	1	Air Cleaner Bowl

Scherer Sentry System

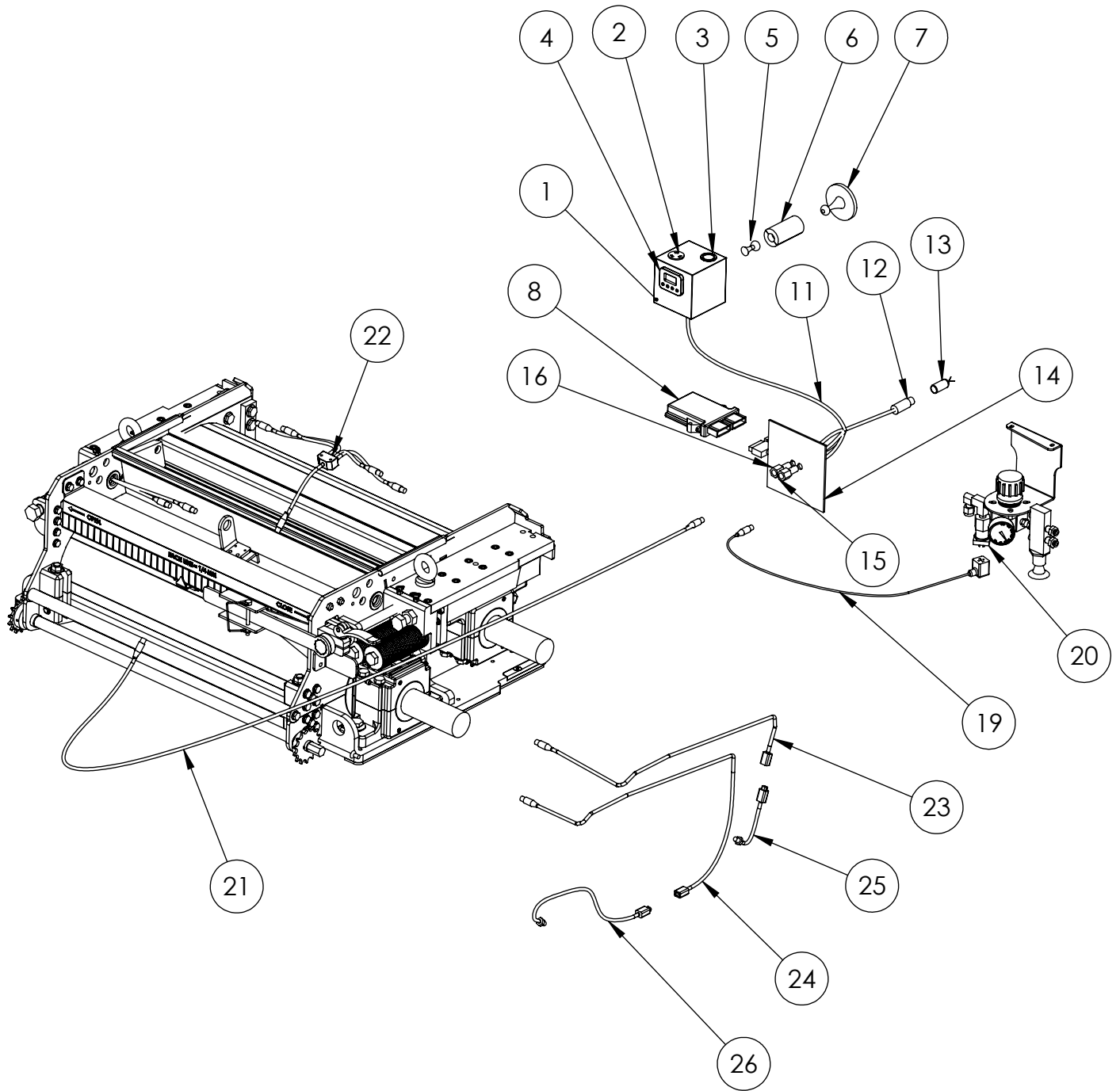

Scherer Sentry System Parts List

	PART #	QTY.	DESCRIPTION
1	PM3024	1	Alarm Enclosure
2	PM3003	1	Audible Alarm
3	PM3002	1	Mute Button
4	PM2002	1	Display Screen
5	PM1008	1	Alarm Enclosure Mount
6	PM1006	1	Enclosure Mounting Arm
7	PM1007	1	Fixed Post Enclosure Mount
8	PM2003	1	XM 500 Control Box
11	PM3028	1	Main Cab Wire Harness
12	PM3001	1	Male Main System Power Plug
13	PM3005	1	Female Main System Power Plug
14	N/A	N/A	Fire Wall of Forage Harvester
15	PM3011	1	8-Pin Power Feed
16	PM3012	1	5-Pin Power Feed
19	PM3020	1	Air Pressure Monitoring Cord
20	PM0011	1	Air Pressure Monitor Switch
21	PM3014	1	Kernal Processor Monitor Cord
22	PM3025	1	Kernal Processor Bearing Monitor Splitter
23	PM3026	2	Short Temp. Monitor Cord
24	PM3027	2	Long Temp. Monitor Cord
25	PM2007	2	Front Temp. Sender Assembly
26	PM2007.1	2	Rear Temp. Sender Assembly

Scherer Sentry 2.0

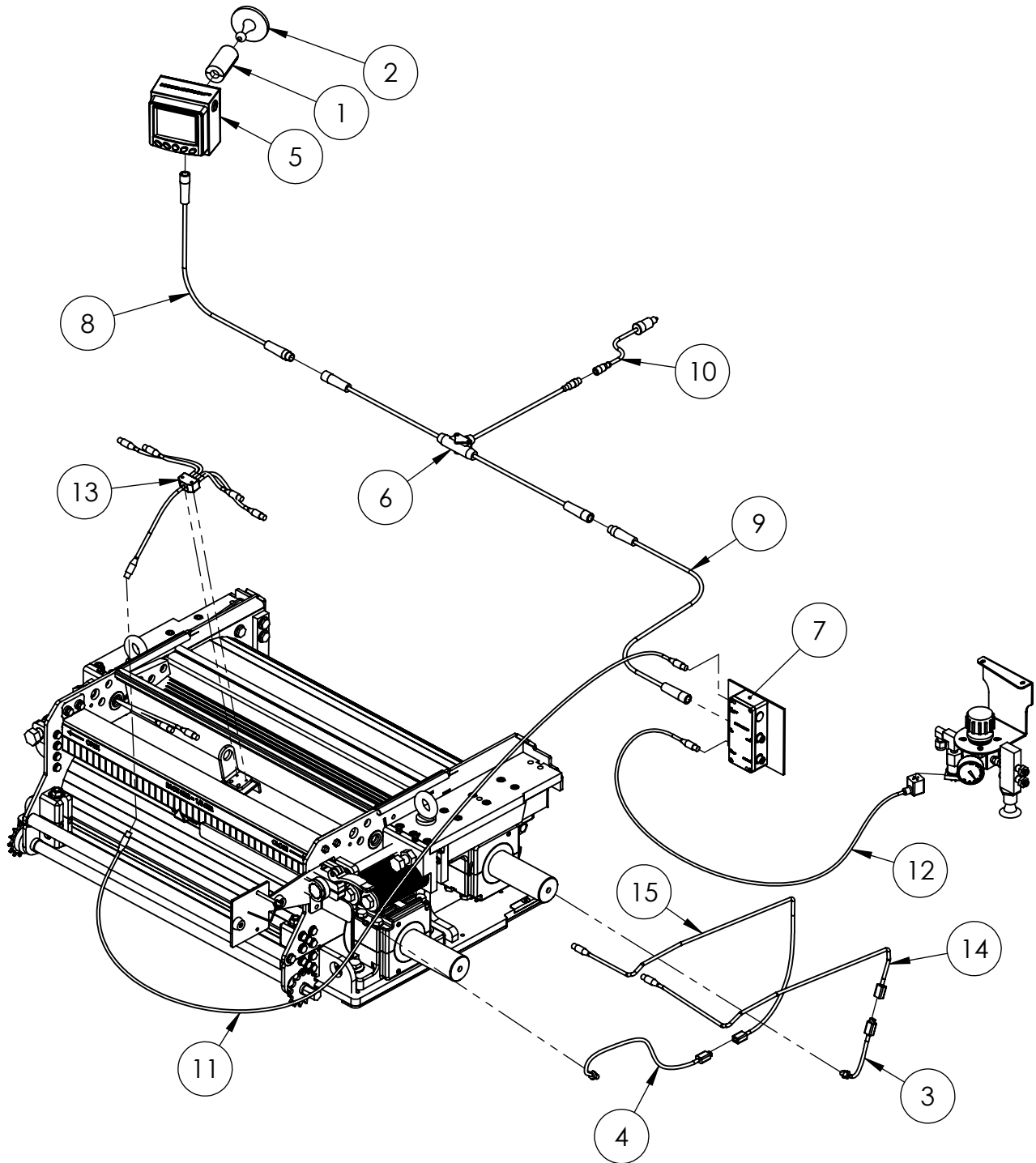

Scherer Sentry 2.0

ITEM NO.	PART NUMBER	DESCRIPTION	QTY.
1	PM1006	ENCLOSURE MOUNTING ARM	1
2	PM1007	FIXED POST ENCLOSURE MOUNT	1
3	PM2007	Front Temp. Sender Assembly	2
4	PM2007.1	Rear Temp. Sender Assembly	2
5	PM21001	CONTROL BOX	1
6	PM21002	TEE ADAPTER	1
7	PM21004	DISTRIBUTION BOX	1
8	PM21006	SHORT EXTENSION CABLE	1
9	PM21007	LONG EXTENSION CABLE	1
10	PM23030	POWER ADAPTER	1
11	PM3014	EXTENSION CABLE	1
12	PM3020	AIR MONITOR CABLE	1
13	PM3025	Kernal Processor Bearing Monitor Splitter	1
14	PM3026	Short Temp. Monitor Cord	2
15	PM3027	Long Temp. Monitor Cord	2

Pneumatic System Install

1. Install pneumatic cylinder with provided hardware as shown.



2. Install regulator mounting bracket (HPD1403) as shown on adjacent wall to right of chute. Route air hoses down to pneumatic cylinder. The ¼ inch hoses can be switched in order to get the desired position. Set pressure to 80-85 psi for 6-Groove Drives, 90-95 psi for 7-Groove.



3. Connect supply hose to the CLAAS air hose as shown, using provided "T" fitting (HPD1349). You will have to cut $\frac{3}{4}$ " out of the CLAAS hose in order to install "T" fitting. Route supply hose up and between cab and chute using provided wire-ties in order to connect to the provided air pressure regulator.

Additional shut off valve
for an air horn. (Optional)

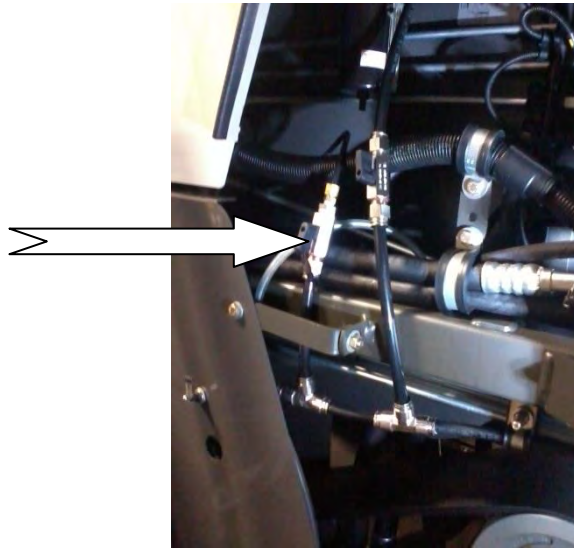

4. If the CLAAS machine does not have urea system, an in line air filter (HPD1411) will need to be installed.

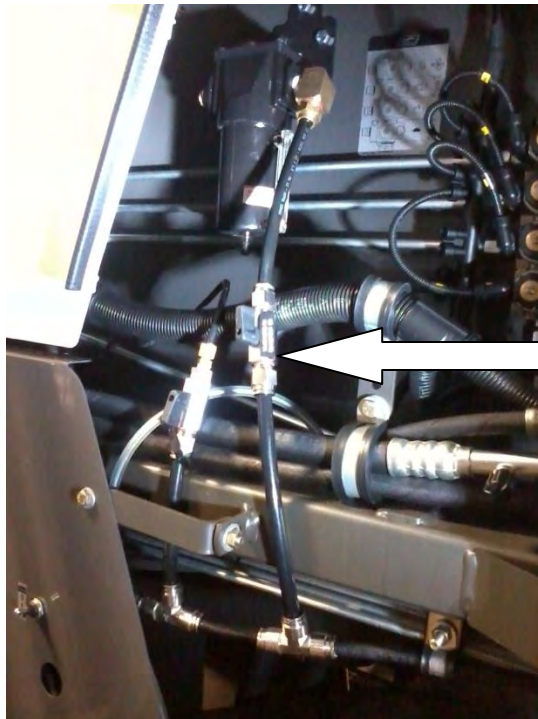

Valve being referenced for air
supply.

5. Use the air filter bracket (HPD1414) as a template inside the processor compartment. Start by measuring from an existing hexagon hole already in the sheet metal. Measure 7" back and 1.5" down for placement of the first hole. Drill the other two holes as needed.



6. Install filter assembly with provided hardware. Cut HPD1361 to length and connect $\frac{1}{4}$ turn valve assembly (HPD1359) to the air filter assembly (HPD1411) as shown.



7. Use provided cable ties to route supply hose (HPD1348) behind cab and over to the regulator assembly for the drive system (HPD1385). Splice into HPD1348 to provide air to the LubriMist system.



'496/'467 Pneumatic System Install

1. Install pneumatic cylinder with provided hardware as shown.



2. Install regulator mounting bracket (HPD1403) as shown on adjacent wall to right of chute. Route air hoses down to pneumatic cylinder. The ¼ inch hoses can be switched in order to get the desired position. Set pressure to 80-85 psi for a 45mm accelerator shaft and 90 psi for a 55mm & 60mm accelerator shaft.



3. Connect supply hose to the CLAAS air hose as shown, using provided "T" fitting (HPD1349). You will have to cut $\frac{3}{4}$ " out of the CLAAS hose in order to install "T" fitting. Route supply hose to the coalescing filter. Then route the air line from the coalescing filter up to the KP compartment.

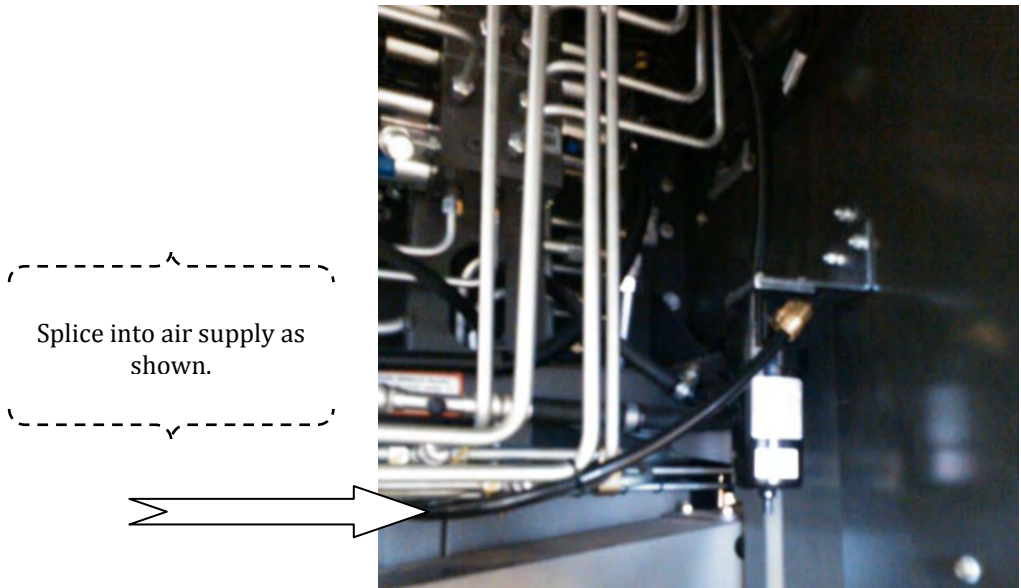

4. Route the air line through one of these plastic grommets. I cut the center out of one to give the air line some additional protection against chafing.

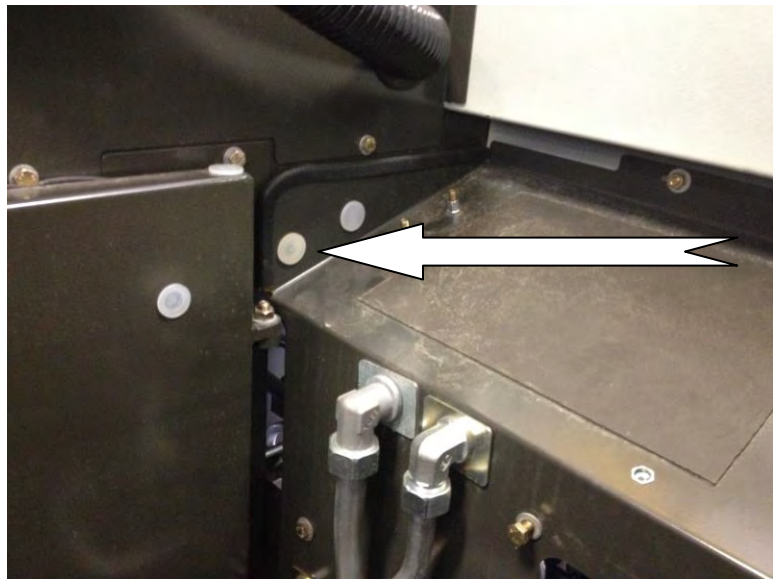

Cut out center of grommet to route air line.

5. Use the LubriMist as a template to drill holes for mounting. Start by measuring 2" from the left hand side of the mounting plate as shown below. Then measure 3" up from the bottom as shown. Drill four holes and use provided hardware to attach the LubriMist to the mounting plate. This placement is important so the bolts don't interfere with hydraulic lines!!



6. Install the LubriMist as shown. Also route air line as shown. Air line will route around the KP compartment and in front of the discharge chute and terminate at the regulator assembly for the tension cylinder (HPD1385). If the machine has a hydraulic belt tension assembly, terminate the air line at the LubriMist.

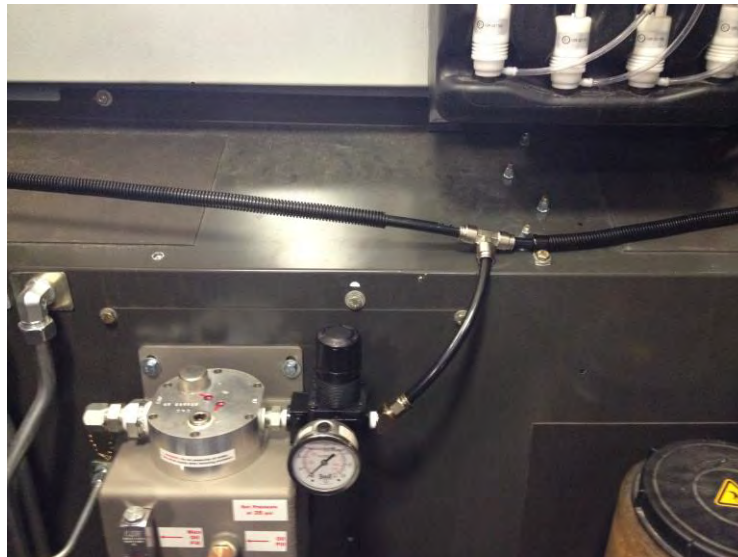

7. Route blue air line as shown below.

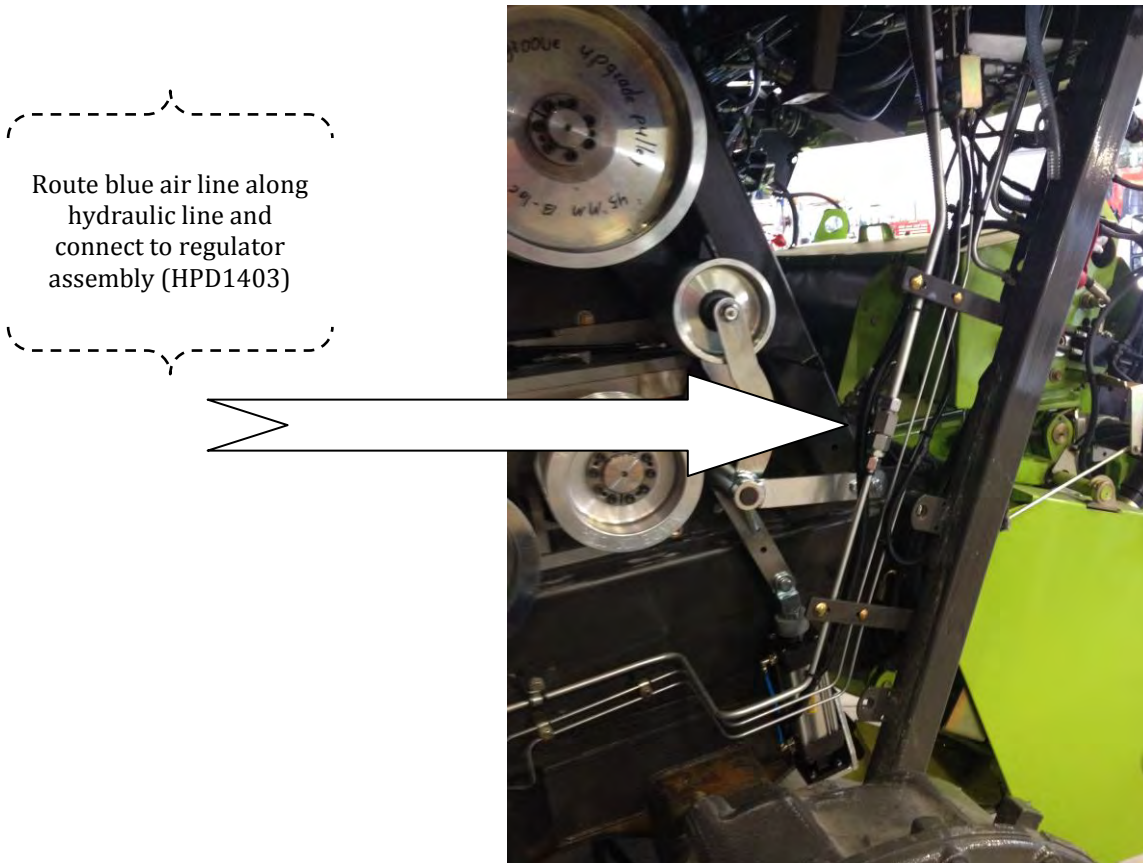

8. Before the processor is installed into the harvester, remove carriage bolts from the bottom of the accelerator and turn them around as shown below. This provides enough room for the processor to slide into position.



Before



After

Claas™ 498 pneumatic install instructions



fig 1a



fig 1b



fig 1c

1. Locate 90° fitting under the left-hand hood, in fig 1b. Remove the 90° fitting, and replace it with a "T" part # 316-4090/HPD1424. Take the 90° fitting that was removed and install it on the open end of the "T". Install the adapter fitting (HPD1423), then install the union (HPD1422), and the pushlock fitting (OM-1025). From there run a short piece of supplied plastic air-line, and install the ¼ turn valve. Fig 1c.

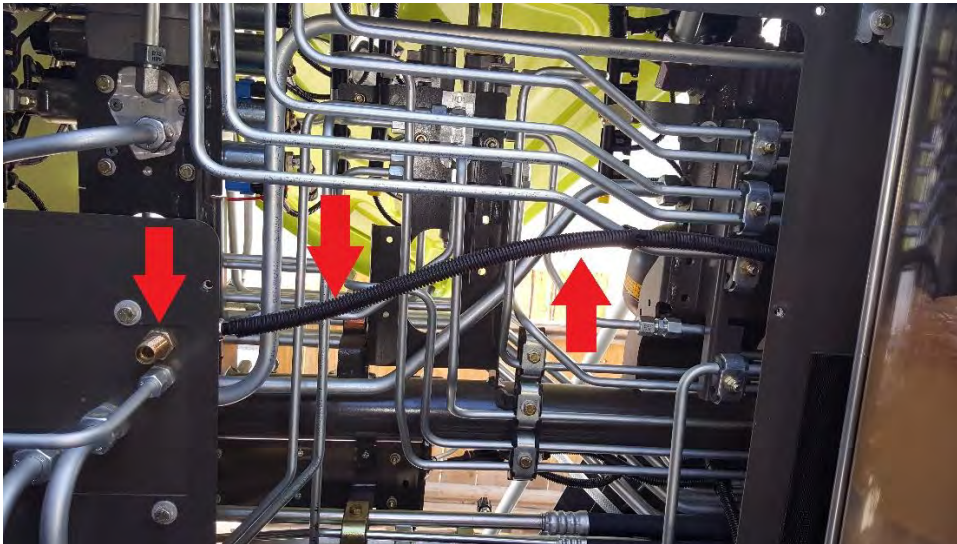

fig 2a

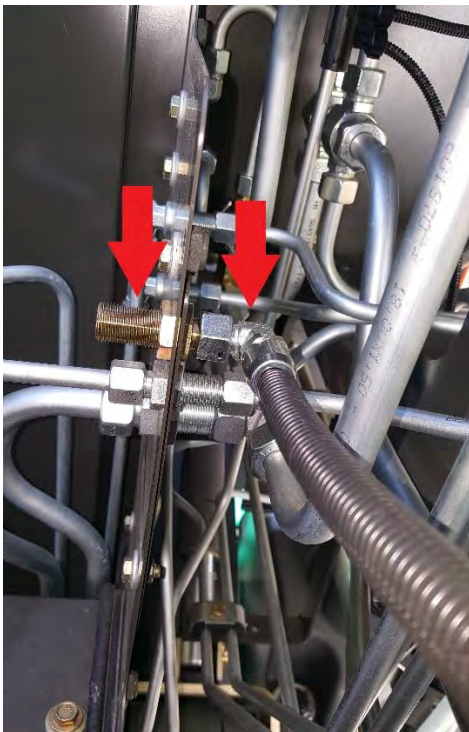

fig 2b

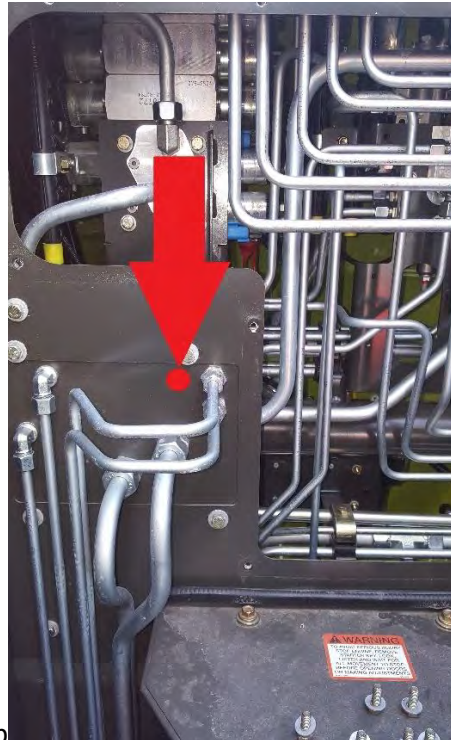

fig2c

2. Remove the service panel, in the KP service compartment. Drill a hole and mount the threaded bulkhead fitting (249-7520 & 213-4770/HPD1425) as shown in fig 2a. Install a 90° fitting (249-8350/HPD1420) on the back of the bulkhead fitting. Take the supplied air-line, and route it from the ¼ turn valve, to the 90° fitting on the back of the bulkhead. **Note if machine has diff lock, you can install the bulkhead back 2" to clear the added air-line fig 2c.**



fig 3a

3. With the service panel off, drill and mount the lubrimist™, and the coalescing filter assembly, as shown in fig 3a. Install the 90° fitting on the other side of the bulkhead connector. Bolt the service panel back onto the chopper. Run a small piece of air-line from the fitting on the bulkhead, to the coalescing filter, run another section of line, from the filter to the lubrimist™ assembly. **Note there is an arrow, on top of the lens on the filter, that shows the direction of air flow Fig 3a.** Also note the fitting diagram on fig 3b.

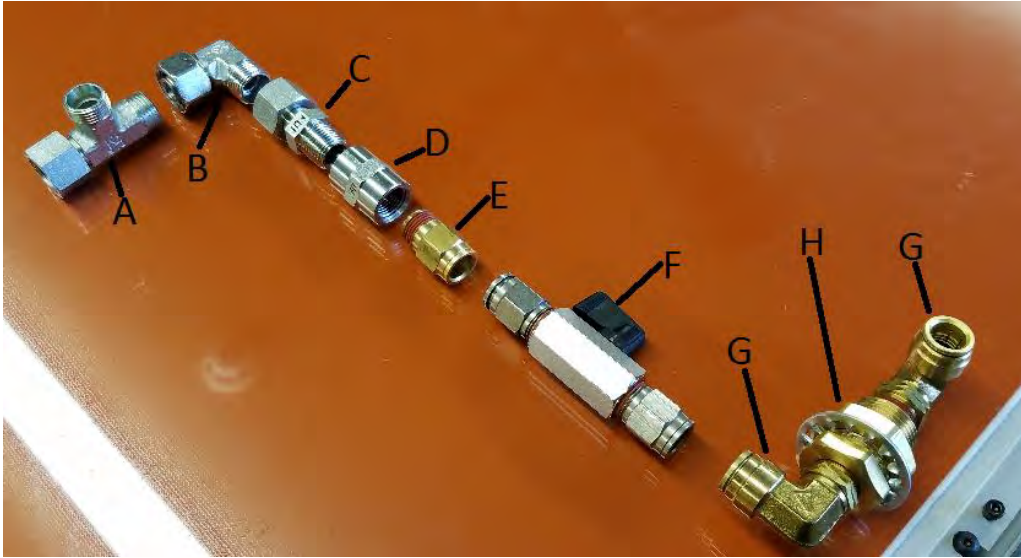

Fig 3b

- A. HPD1424 "T"
- B. Fitting that was removed to install "T"
- C. HPD1423 Conversion Fitting
- D. HPD1422 Union
- E. OM1025 Pushlock Fitting
- F. HPD1359 1/4 Turn Valve
- G. HPD1420 90° Swivel Fitting
- H. HPD1425 Bulkhead Fitting

Sentry 2.0 Install Instructions

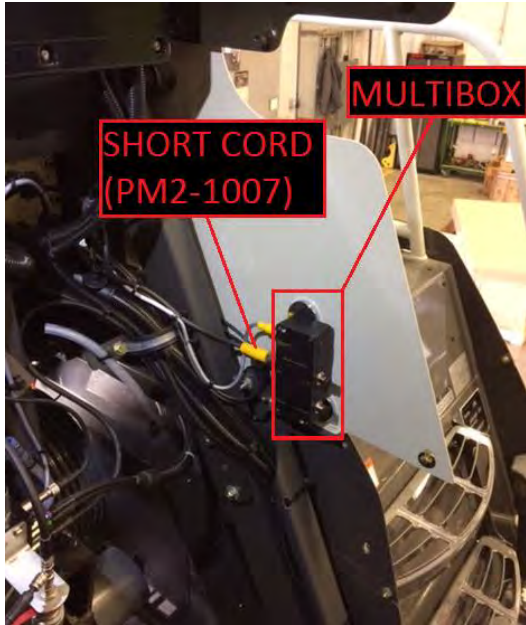

fig 4a



fig 4b

4. Install the sentry system. Start by taking the multibox, and place it on the inside of the right hand exterior panel. Fig 4a. Next take the upper cab pass-through cover off, and drill a 3/4" hole in it. Take the short cord (PM2-1007), and route it from the multibox through the hole drilled in the pass-through cover. Now take the supplied grommet, cut it and wrap it around the cable, and tuck it into the drilled hole. Make sure to put silicone around the grommet, to keep debris out of the cab. Fig 4b.



fig5a



fig 5b

5. Under the right hand control arm in the cab, remove the cover for the electrical cabinet. Take the supplied "T" (PM2-1002), and place it into the electrical cabinet. Connect the short cord (PM2-1007) to one of the larger connectors on the "T". fig 5a. Connect the long cord (PM2-1006) to the other large connector on the "T". Remove one of the access plugs, located under the ignition switch, and route the long cord (PM2-1006) through the access hole. Fig 5b.



fig 6a



fig 6b

- Now mount the monitor, it can be mounted to the interior "A" panel using the supplied mount (PM-1007), and sheet metal screws. Fasten the mount directly to the plastic on the "A" pillar using the supplied screws. Fig 6b. The mount can also be fastened to the rail mount if so desired. Fig 6a.



fig 7a



fig 7b

- Take the mounting clamp (PM-1006) and use it to connect the display screen to the monitor. Fig 7a. Take the long cable (PM2-1006), and route it along the rail mount using zip ties. Fig 7b.



fig 8a



fig 8b

8. Take the supplied power cord end (PM2-3030). Connect it to the small connector on the “T”, and plug it into the outlet above the electrical cabinet. **Note that only one of the outlets is keyed power, the other outlet is constant power.** Once you have everything plugged in, go ahead and install the electrical cabinet cover, routing the cord through as shown in fig 8a. Turn the ignition switch, and the monitor on. Check to make sure the monitor has power. Fig 8b.

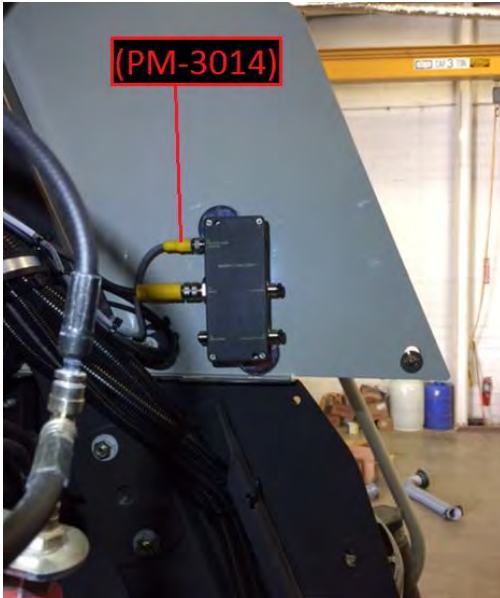

fig 9a

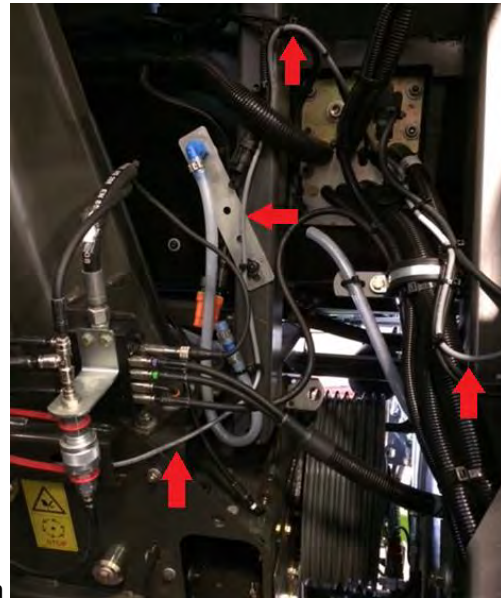

fig 9b

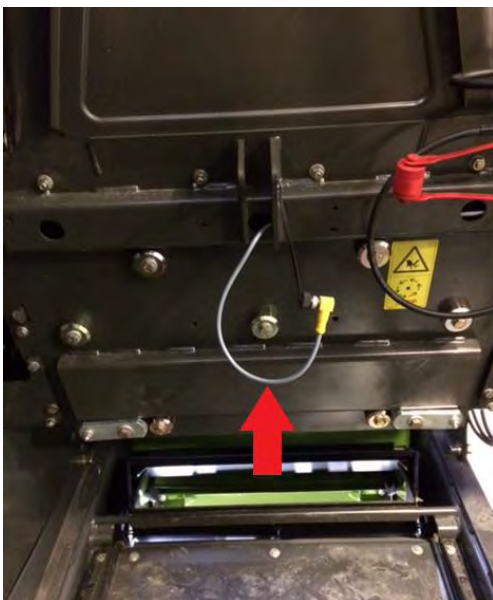

fig 9c

9. Route the cable that connects the KP to the Multi box (PM-3014). Connect the cable to the multibox. fig 9a. Route the cable along the wiring harnesses, and grease lines on the machine, as shown in fig 9b. Run the cable through the brace on the accelerator back plate. Fig 9c. once the

KP is installed, connect the PM-3014 cable to the KP. Enter the cab, turn on the ignition switch, and the monitor, make sure you have a reading on all four bearing temperatures.



fig 10a



fig 10b

10. In the front of the KP service compartment, remove the clevis pin from the sharpening door cylinder. Take the supplied template fig 10a (Part #HOD1404), and line it up with the outside of the bracket. fig 10b. Use two locking pliers or a c-clamp, to hold the template in place. Insert the clevis pin through the top holes to help line it up.



fig 11a



fig 11b

11. Take a 1/2" drill bit, and drill two holes in the bracket on the chopper, using the template as a guide. Once you have the holes drilled, spray paint over the dotted lines on the template, and

repeat this process on the other mount. **Be sure to cut notches on the top, and bottom of the mount, so it will not interfere with the cylinder, once its assembled. Fig 11a, Fig 11b**

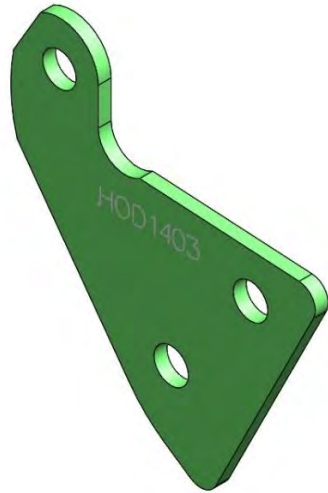

fig 12a



fig 12b

12. Now take the supplied mounting ears fig 12a (Part #HOD1403), and bolt them to the brackets on the chopper using the holes drilled in the previous step. Take the longer supplied clevis pin and mount it through the cylinder. Fig 12b.

Scherer Sentry Operational Guidelines

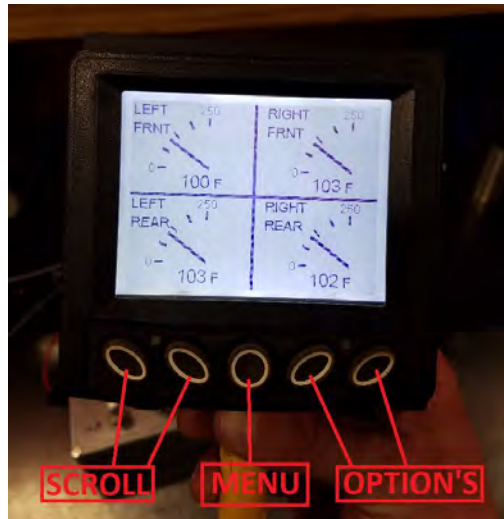

- 1) The Sentry is set up to have 2 levels of alarm: warning and shutdown.
- 2) Warnings will only provide an amber light on the left corner of the display and an alarm screen with a description of the alarm.

Warnings - bearing temps $> 180^{\circ}$ but $< 200^{\circ}$ F.

- 3) Shutdown alarms will provide an alarm screen with a description of the alarm, a red light at the bottom right corner of the display, and an audible alarm.

Shutdown - bearing temps $> 200^{\circ}$ F.

- 4) To silence the audible alarm depress the button on the far right on the display. The audible alarm will be silenced for 5 minutes. If another alarm comes in during the 5 minutes you **will not** receive another audible alarm.
- 5) To clear the alarm screen so you can resume monitoring bearing temps press the 'HIDE' button on the display, far right.
- 6) Normal operating range (after break-in) is 120° - 175° F.

NOTE – The sentry will display a description screen for every warning or alarm received even if the issue has been resolved. If neither the amber nor red light on the bottom of the Sentry is illuminated there is **no longer** an alarm situation. It makes you acknowledge the alarm screen so you know at one time there was an issue.

Scherer Design Engineering, Tea SD 1-800-883-9790

After hours: Bob 605-201-1926 Jim 605-940-6356 Jason 605-941-3458 Lyndon 605-941-0502

The initial start-up screen for the Scherer Sentry lists an after hour.

TROUBLESHOOTING THE SCHERER SENTRY™

Issue	Cause	Solution
Some bearing temps are reading NO DATA	Wire harness has a loose connection	Make sure all threaded connections (inside firewall, outside firewall, at the processor, and after the splitter) are finger tight.
Low air pressure alarm will not turn off	Too high of setting on air sensor or low system air pressure	Check system air pressure. With the actuator cylinder RETRACTED adjust the belt tensioning pressure up to 120 psi. If there is 120 PSI available the sensor needs adjustment, contact Scherer Design. A temporary fix is to unplug the sensor.
Running a new processor and the bearing temps are above normal operating temp	Bearings are breaking in	New processor bearings need to “break-in”. Normal break-in temps may be up to 200°F. Within 30-40 hours bearing temps should return to normal operating range (120°-175°F).
Some bearing temps are reading NO DATA	Temp sender may be faulty or temp is above 275°	Replace temp sender if faulty.
Display reads “CAN BUS FAILURE”	Bad harness connection between display and XM 500 control module	The XM 500 is mounted in the cabinet under the arm rest. Make sure both plugs are firmly seated in the module. Next, access the back of the display and ensure the plug in firmly seated. If not resolved contact Scherer Design.
Display reads “0.00 H”	Display is set up as “1-up” display	Press ‘Menu’, scroll to highlight ‘GO TO 4-UP DISPLAY’, press ‘Enter’
Display reads in Degrees F	Menu is set to English units	Press ‘Menu’, scroll down to highlight ‘SELECT UNITS’, press ‘Enter’, scroll to highlight your unit of measure, press ‘Enter’, press ‘Menu’ twice to return to 4-up display.

Scherer Sentry Operating Notes

1. When powered up the Sentry will automatically display 4 temps from the processor bearings.
2. The Sentry is set up to have 2 levels of alarm: warning and shutdown
3. Warnings will only provide an amber light on the bottom left corner of the display, and an alarm screen with a description of the alarm. Warnings include: bearing temps > 180 but < 200° F. (to switch to degrees Celsius enter the menu screen by pressing the center button twice, use the 2 buttons on the left hand side of the display to scroll to "UNITS", use the 2 buttons on the right hand side of the display to select "METRIC BAR", press the center button again to accept the changes)
4. Shutdown alarms will provide an alarm screen with a description of the alarm. Shutdown alarms include: bearing temps > 200°F, oil alarm > 1 minute, system air pressure < 85 PSI.
5. To silence the audible alarm, depress the button on the far right twice. The audible alarm will be silenced for 5 minutes. If another alarm comes in during that 5 minutes you will not receive another audible alarm.
6. To clear the alarm screen so you can resume monitoring bearing temps press the right button on the display.

Scherer Design Engineering, Tea SD 1-800-883-9790

After hours: Bob 605-201-1926 Jim 605-940-6356

Jason 605-941-3458 Lyndon 605-941-0502

The initial start-up screen for the Scherer Sentry lists an after hour.

7-groove Drive Kit Install

1. Remove right front tire from the forage harvester.
2. Remove shield from wheel well.
3. Install grease tube (D1337 or D1337L) with the grease tube male adapters (D1336) to the base of the idler shaft on the forage harvester. Then install the grease fitting (D1338). The grease tube will need to be bent and formed by hand in order to fit correctly. Fill the grease tube with grease using a grease gun till the grease comes out of the hole on the shaft.
4. Install main drive idle pulley assembly (D1332-7). The idle shaft will have to be cleaned and you may need to use emery cloth and a degreaser to ensure a smooth surface for the bearing to slide on. 3 spacers (D1334-7) are provided to be placed on the shaft prior to installing the idler pulley. The use of these spacers may depend on the alignment of the belt and pulley system. Spacers can be added or taken away as needed.
5. Install idler shaft cap (D1338-7) with a 16mm washer (D1327) and a 16 x 45mm bolt (D1326) and torque to 80 ft/lbs. After the pulley is installed, give the grease zerk 2 pumps. The idler pulley comes pre-greased from the factory.
6. Install grooved main drive pulley. Depending on the model of forage harvester you have, there are three different accelerator pulley options. Refer to pages 15 & 15A to reference pulley sizes. Again the shaft will need to be cleaned with a degreaser and emery cloth may need to be used to get a clean and smooth surface to ensure a secure lock to the pulley. Place the main drive pulley onto the accelerator shaft with the locking hub still in place and align the main drive pulley to the lower idler pulley since the idler pulley is fixed. If proper alignment is not obtained, spacers (D1334-7) will need to be added or taken away to facilitate the proper alignment of the system. It is critical to obtain alignment $\pm 1/16$ in. After the pulleys have been properly aligned, the locking hub will need to be tightened. Torque bolts of the locking device to 32ft/lbs. Torque bolts in a clockwise rotation and go around the locking hub 3 to 4 times to ensure proper torque. Alignment can also be made easier by using a laser alignment tool (A1010) available through SCHERER.
7. Install the tension arm (HPD1307-7). The shaft may need to be cleaned and you may need to use emery cloth and a degreaser to ensure that the shaft is clean and smooth. The tension arm can be slid on to the shaft and washers (D1312) are provided for alignment as needed.
8. Install the pivot tube brace (HPD1373).

9. Mount the pneumatic cylinder bracket (HPD1346-7) in place of the spring tension bracket on the forage harvester. Bushings (D1323), a washer (D1324), and a snap ring (D1325-7) are provided if needed.

10. Install the pneumatic tension cylinder (HPD1341). The base of the cylinder should be connected to the pneumatic cylinder bracket (HPD1346-7) and the other end should be connected to the tension arm (HPD1307-7). Make sure that the swivel fittings (HPD1354) are facing the rear of the forage harvester when the pneumatic cylinder is installed. This allows for access to the cylinder and fittings from inside the forage harvester.

11. Set the processor pulleys to align with the drive system. Once the Scherer Processor is in place and properly aligned; the grooved processor pulley should be loosened and aligned with the main drive grooved pulley and the idle pulley. This alignment is very critical and should be within $\pm 1/16$ in. After the grooved processor pulley is in place, the smooth processor pulley can be aligned to the rest of the drive system. The locking hubs on the processor should be tightened the same way as the main drive pulley locking hub making sure that the shoulder of the locking hub is pressed firmly against the center disc of the pulley. Torque the locking hubs to 32 ft/lbs(Page 41). Torque in a clockwise pattern and go around tightening every bolt. Continue torqueing in a clockwise pattern 3 to 4 times. This will ensure all bolts are at the appropriate torque.

Roll Change Instructions

1. Remove processor from the forage harvester. An air wand will also help keep things clean and free from debris.
2. Take a measurement from the frame to the pulley on the roll to be replaced so you know where to place the pulley on the new roll since pulley alignment is critical.
3. Clean the bolt heads of the locking hub and remove the pulley from the roll that needs to be replaced.
4. Loosen the two latch block eye bolts (B1037).
5. Remove the middle hinge bolts (HPST1011.1).
6. Loosen the top hinge bolts (HPST1011.2).
7. Loosen the bottom hinge bolts (HPTB1010).
8. Open processor so the rolls are exposed.
9. Disconnect and remove the temp sensors and the oil line fittings from the bearing castings of the roll to be replaced.
10. Remove bearing housing bolts (TB1008) and (HPTB1010).
11. Remove old roll and clean the bearing casting surface on the frame of the processor from debris.
12. Install new roll and use bearing housing bolts (TB1008) to align the bearing castings and torque to 12 ft/lbs. The drive side bearing casting will be locked in place so align the drive side bearing casting first. The idle side bearing will slide within the bearing housing so the idle side bearing housing will be able to be slid into place and align with the bolt holes after the drive side is in place.
13. Install bearing housing bolts (HPTB1010) and torque to 170 ft/lbs.
14. Install oil fittings and oil lines as well as the temp sensors.
15. Close the processor and watch oil lines and wires so they don't get pinched between the two halves of the frame.
16. Install and tighten 1/2" hinge bolts (HPST1011.1 & HPST1011.2) and torque to 70 ft/lbs.
17. Tighten the lower hinge bolt (HPTB1010) and torque to 170 ft/lbs.
18. Tighten latch block eye bolts (B1037) and torque to 65 ft/lbs.

Bearing Removal and Installation

1. To disassemble housing, in order to remove bearing, remove the 4 bolts on housing as seen in Fig. 1A. Tap on feet of housing with a soft mallet to separate the two halves.
*****Note: Keep the 2 halves of housing together as they are machined in pairs and are numbered accordingly.**



2. To remove bearing, place the bearing removal tool(A0009 or A0022) over bearing and shaft and remove bearing as shown in Fig. 2A (If there is a snap ring present, be sure to remove it prior to pulling bearing)

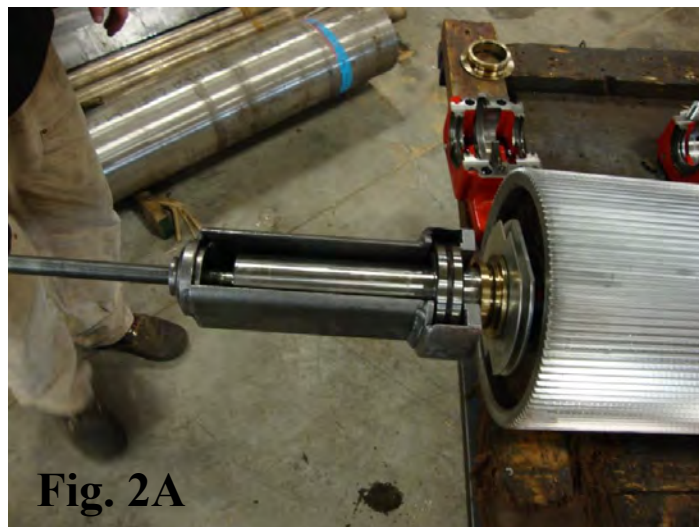

Bearing Installation

Please follow these instructions and SKF Bearing instructions to get the optimum performance from your bearings.

3. Slide on spool seal, hub side in. You can use a small amount of grease on shaft and be sure your spool seal is in good condition (See Fig. 1A).
4. Slide on inner bearing housing (brass) seal, using grease and making sure 2 “O” rings are in place. (See Fig. 2A).

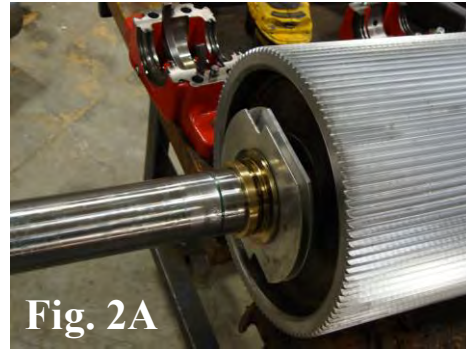

5. Heat bearing to 230 degrees F. (See Fig. 3A)
6. Slide bearing onto shaft all the way to the relief groove. If the bearing gets jammed, pull the bearing off again with the removal tool and re-heat the bearing. (See Fig. 4A)

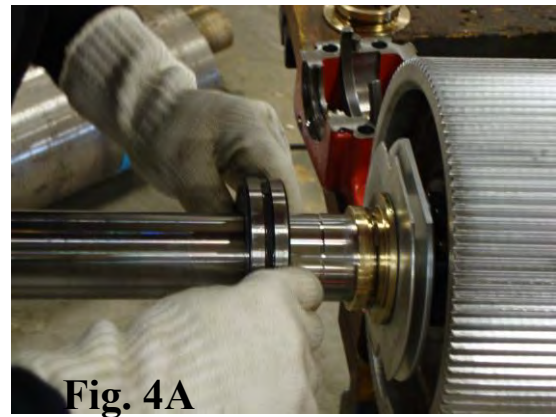

Bearing Installation

- Slide on outer bearing housing (brass) seal. (Fig. 5A)
- On short end you will not use an outside seal, as the housing end is closed as seen in 9B.

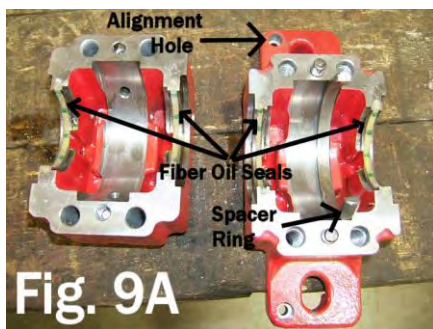
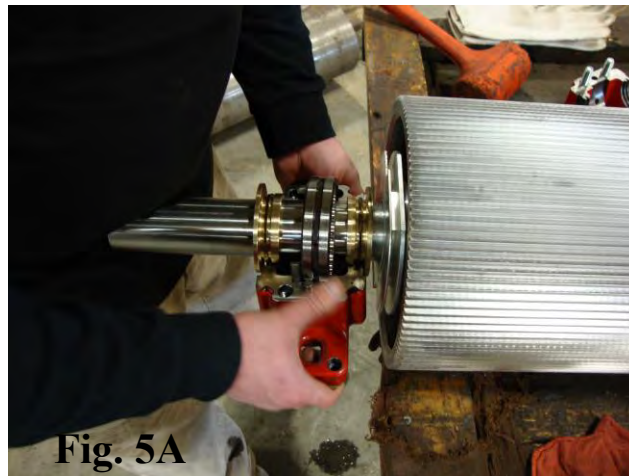

- The housings are next. Install fiber oil seals as shown in Fig. 9A and Fig. 9B. **Install with marked side facing toward roll shaft.** Trim off any excess fiber material with utility knife.

Bearing Installation

10. Bearing housings are machined as matched and numbered pairs. **THE TOP AND BOTTOM OF HOUSING MUST HAVE THE SAME NUMBER.**
11. Install lower housing. Install cap on lower housing by tapping in place with a soft mallet. (See Fig. 11A, 11B & 11E for drive end installation. See Fig. 11C, 11D & 11E for short end install.)

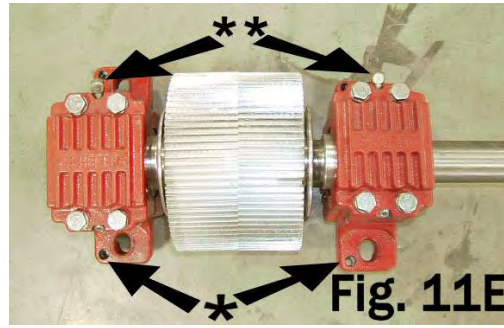
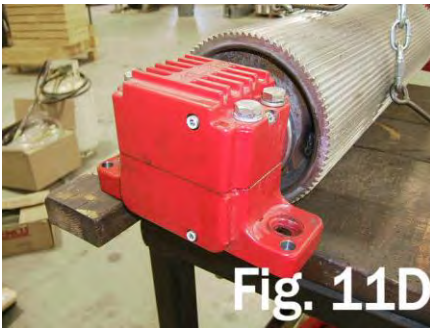
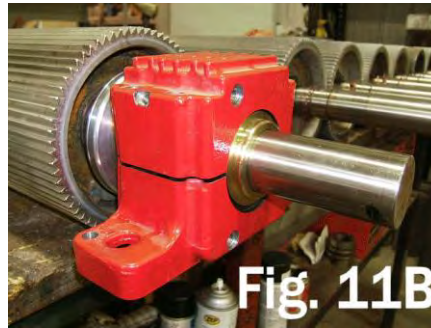
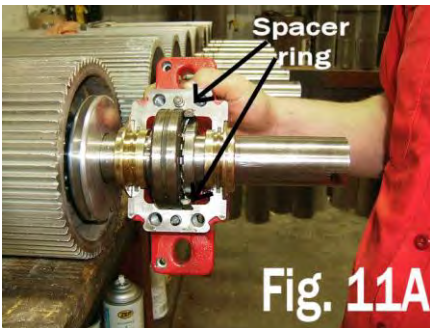

* With Drive End of shaft on right side, be sure alignment hole location corresponds with the location shown

12. Tighten bolts and check for free movement of bearing within the housing. After bolts are tight, on short shaft end, you should be able to slide the entire bearing housing in and out $\frac{3}{8}$ of an inch by hand. **THIS MOVEMENT IS IMPORTANT.**
13. Fill bearing housing with 3 oz. of oil by using a squirt bottle, small funnel, or whatever method you find suitable. Repeat this with all housings

Common Torque Specs

Bearing Housing Bolt (HPTB1010)	170 ft-lbs	230 N-m
Bearing Housing Bolt (TB1008)	12 ft-lbs	16 N-m
Bearing Housing Bolt (R1230)	75 ft-lbs	100 N-m
Spring Rod (HPST1003S)	220 ft-lbs	300 N-m
Spring Bolt (B1001)	210 ft-lbs	285 N-m
Latch Block Eye Bolt Nut (B1038)	65 ft-lbs	88 N-m
Hinge Bolt (HPT1011)	70 ft-lbs	95 N-m
Idle Pulley Bolt (D1326)	80 ft-lbs	108 N-m
Taper Locking Hub (All Sizes) <u>Page 45</u>	xx ft-lbs	xx N-m

Maintenance Intervals

1. After your Scherer Processor is installed

- Set your roll gap (See roll gap adjustment on page 5)
 - Pass product through the machine, at least 5 loads under full power.
 - Adjust rolls to your processing needs; however, The Scherer Processor is not intended to be run against the roll stops so adjust accordingly.
 - Check adjustments 5 to 10 hours later to ensure adjustments are holding at your desired position. Check pulley alignment and make sure locking hubs are firmly in place.
 - Check air tension on drive belt and set air pressure according to specific model.
 - 6-groove drive: 80 to 85psi
 - 7-groove drive: 90 to 95psi

2. 50 Hours

- Grease adjustment bolt zerks on processor (2 pumps)
- Grease lower idle pulley on drive system (D1332-7) and tension pulley (D1305-7) 2 pumps each.
- Visually inspect for damage to springs, bolts, shafts, pulleys, wiring, oil lines, etc.

3. 250 Hours

- Visually inspect for damage to springs, bolts, shafts, pulleys, wiring, oil lines, etc.
- Roll back processor and visually inspect rolls, roll gap, and the overall condition of the processor.
- If roll gap is wider at one end, this could be an indication of a bearing failure or other unknown problems. There is also a possibility that the rolls just need to be adjusted.

4. End of Season (VERY IMPORTANT)

-End of season maintenance will help reduce bearing failures and greatly reduce down time while harvesting.

-Use air to clean off the Processor.

-If you decide to power wash the processor, immediately dry the processor and open it to expose bearing castings and rolls. After power washing, there is a good possibility that water penetrated the seals of the bearing and bearing damage would be imminent. After power washing the processor, you can prevent bearing damage by immediately servicing the processor and following the next few steps.

-Remove the tops of the bearing castings with a soft mallet and inspect the condition of the oil and bearing. Be very careful with the mating surfaces of the castings since they are machined surfaces and keep the top half with the bottom half since they are machined as a mating pair and are numbered accordingly.

-If there is no contamination, simply remove the old oil and replace the felt seals (HPR1009).

-If contamination is present, the bearing casting needs to be removed and cleaned thoroughly. The oil line and the temp sender should be removed in order to clean the casting. New felt can then be installed. The bearing may also need to be replaced if there is a substantial amount of contamination in the bearing casting. An inspection of the bearing rollers may also help determine if the bearing needs to be replaced.

-Make sure all bearings get 3 oz. of fresh Chevron Cetus HyperSyn ISO 32 oil after they have been inspected or changed.

-Inspect spool seal (HOR1011) for wear.

-Coalescing Filter

Inspect and/or replace filter element (HPD1411.1) after each season.

Scherer Sentry Operational Guidelines

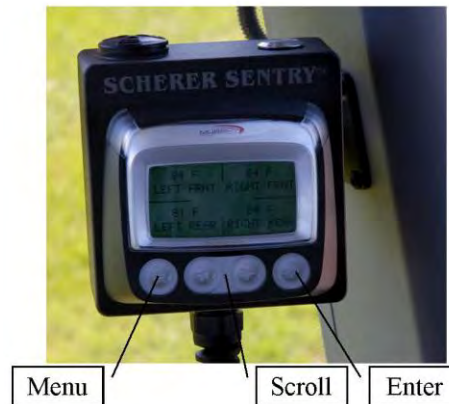

- 1) The Sentry is set up to have 2 levels of alarm: warning and shutdown.
- 2) Warnings will only provide an amber light on the left corner of the display and an alarm screen with a description of the alarm.

Warnings - bearing temps $> 180^{\circ}$ but $< 200^{\circ}$ F.

- 3) Shutdown alarms will provide an alarm screen with a description of the alarm, a red light at the top right corner of the display, and an audible alarm.

Shutdown - bearing temps $> 200^{\circ}$ F, oil alarm > 1 minute, system air pressure < 85 PSI.

- 4) To silence the audible alarm depress the lit button next to the horn on top of the display. The audible alarm will be silenced for 5 minutes. If another alarm comes in during the 5 minutes you **will not** receive another audible alarm.
- 5) To clear the alarm screen so you can resume monitoring bearing temps press the 'Enter' button on the display.
- 6) Normal operating range (after break-in) is 120° - 175° F.

NOTE – The sentry will display a description screen for every warning or alarm received even if the issue has been resolved. If neither the amber nor red light on top of the Sentry is illuminated there is **no longer** an alarm situation. It makes you acknowledge the alarm screen so you know at one time there was an issue.

Scherer Design Engineering, Tea SD 1-800-883-9790

After hours: Bob 605-201-1926 Jim 605-940-6356 Jason 605-941-3458 Lyndon 605-941-0502

The initial start-up screen for the Scherer Sentry lists an after hour.

TROUBLESHOOTING THE SCHERER SENTRY™

Issue	Cause	Solution
Some bearing temps are reading NO DATA	Wire harness has a loose connection	Make sure all threaded connections (inside firewall, outside firewall, at the processor, and after the splitter) are finger tight.
Low air pressure alarm will not turn off	Too high of setting on air sensor or low system air pressure	Check system air pressure. With the actuator cylinder RETRACTED adjust the belt tensioning pressure up to 120 psi. If there is 120 PSI available the sensor needs adjustment, contact Scherer Design. A temporary fix is to unplug the sensor.
Running a new processor and the bearing temps are above normal operating temp	Bearings are breaking in	New processor bearings need to “break-in”. Normal break-in temps may be up to 200°F. Within 30-40 hours bearing temps should return to normal operating range (120°-175°F).
Some bearing temps are reading NO DATA	Temp sender may be faulty or temp is above 275°	Replace temp sender if faulty.
Display reads “CAN BUS FAILURE”	Bad harness connection between display and XM 500 control module	The XM 500 is mounted in the cabinet under the arm rest. Make sure both plugs are firmly seated in the module. Next, access the back of the display and ensure the plug in firmly seated. If not resolved contact Scherer Design.
Display reads “0.00 H”	Display is set up as “1-up” display	Press ‘Menu’, scroll to highlight ‘GO TO 4-UP DISPLAY’, press ‘Enter’
Display reads in Degrees F	Menu is set to English units	Press ‘Menu’, scroll down to highlight ‘SELECT UNITS’, press ‘Enter’, scroll to highlight your unit of measure, press ‘Enter’, press ‘Menu’ twice to return to 4-up display.

Sentry Installation Instructions

1) Installing Feed-thru Plugs

Exterior View



- 1) The first step is to remove the 2 medium sized plugs from the cable feed-thru port on the back of the cab. Once the 2 plugs are removed the plates can be put back into place and tightened down.
- 2) Inside the cab you will need to lift the control arm to locate the electric cabinet below it. Remove the lid to the electric cabinet. The cable feed-thru port is located in the rear of the cabinet.
- 3) Locate the 2 feed-thru plugs provided in the kit. It will take two people to install the feed-thru (10 minute process). The yellow 5-pin feed-thru needs to be run from the exterior into the cab. And the black 8-pin feed-thru needs to run from the cab out to the exterior.
- 4) Carefully tighten the feed-thru's.
- 5) Attach the splitter to the yellow 5-pin.
- 6) Secure the protective caps provided for the exterior connections.

Interior View

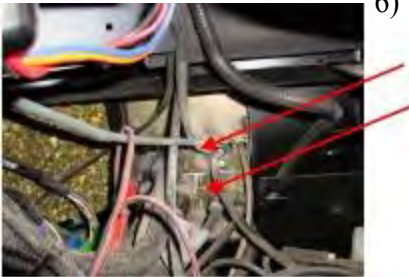

Feed Thru's installed



Scherer 
Design Engineering, Inc.
Tea, SD

2) Installing XM 500 Module

- 1) Locate and clean the location for the XM 500 (module) next to the fuse box (pictured below). The plugs on the module need to face the rear of the chopper.
- 2) You may plug the harness in prior to mounting in place.
- 3) Mount module with supplied velcro.

Module mounted in cabinet



3) Installing display and wire harness

Pillar mount option



- 1) Decide if you would like to mount the display on the window with the suction mount or fixed onto the pillar.
- 2) For suction mount please refer to instructions provided with the mount for proper attachment. Attach the display to the suction base using the mounting arm. Alcohol wipes are included to clean the window prior to attaching.
- 3) For pillar mount first attach the 4 hole mounting base to the display with the mounting arm and choose the best location for your operation. Use the 4 hole mounting base as a template to mark out the location and attach the base with the provided screws. No pre-drilling is necessary.

Suction Mount



5 pin cable attached to feed-thru



- 4) Depending on mounting location choose the best routing to run the cable back to the power accessory ports. Adhesive backed cable clamps are provided to secure the cable along the pillar. Use alcohol wipes to clean surface before applying clamps.
- 5) Route the harness by running both the grey and black 12 pin connectors through the electric cabinet down to the XM 500 module.
- 6) Attach black and grey 12 pin connectors to their respective ports on the module. They are keyed to only install one way.
- 7) Attach the grey 5 pin and 8 pin cords to their respective feed-thru plugs.
- 8) Plug the power cord into the switched port on the back pillar of the cab.
- 9) Run the display cable up the back pillar along with the power cord and replace the lid to the electrical cabinet.



4) Attach cords to sensors (exterior)

- 1) The Air monitoring cable (single plug) will attach to the 5-pin splitter (either port) on the firewall and terminate at the air pressure sensor on the Pneumatic belt tension system control. Be sure to secure the plug to the sensor with the screw to ensure connectivity.
- 2) The Oiler cable will attach to the other port on the 5-pin splitter and attach to the processor oiler. Be sure to secure the plug using the screws.
- 3) The Processor extension cable will attach to the 8-pin feed-thru on the firewall with the right-angled end terminating at the processor. Route wire in a secure path and keep in mind that the accelerator of the forage harvester will suck up any loose wires.
- 4) While the cord is attached to the processor mate the 2 protective caps together to reduce contamination.
- 5) Should you receive a reading of 1 degree for any bearing the system is not connected. Be sure all electrical connections are hand tight.



Operation Notes

- 1) When powered up the Sentry will automatically display the 4 temps from the processor bearings. If the display has been switched to another mode simply enter the menu by pressing the left button on the display and scroll to select “4-up display” and select using the right button.
- 2) The Sentry is set up to have 2 levels of alarm: warning and shutdown.
- 3) Warnings will only provide an amber light on the left corner of the display and an alarm screen with a description of the alarm. Warnings include: bearing temps > 180 but < 200 degrees F. (to switch to degrees Celsius enter the menu screen by pressing the left button, scroll down to “Select Units”, press the right button, scroll down to “Metric BAR”. Press the right button to select, then press the left button twice to exit.)
- 4) Shutdown alarms will provide an alarm screen with a description of the alarm, a red light at the top right corner of the display, and an audible alarm. Shutdown alarms include: bearing temps > 200 degrees F, oil alarm > 1 minute, system air pressure < 85 PSI.
- 5) To silence the audible alarm depress the lit button next to the horn on top of the display. The audible alarm will be silenced for 5 minutes. If another alarm comes in during that 5 minutes you will not receive another audible alarm.
- 6) To clear the alarm screen so you can resume monitoring bearing temps press the right button on the display.

Scherer Design Engineering, Tea SD 1-800-883-9790

After hours: Bob 605-201-1926 Jim 605-940-6356

 Jason 605-941-3458 Lyndon 605-941-0502

The initial start-up screen for the Scherer Sentry lists an after hour.

LUBRIMIST INSTALL



- Drill four holes to mount the LubriMist to the wall. **BE CAREFUL AND CONSCIOUS OF STEEL HYDRAULIC LINES BEHIND THIS WALL.**
- Splice into the air line that feeds the air cylinder for the kernel processor drive belt. Use the “T” and air line provided.
- Connect oil hose on the kernel processor to the LubriMist.
- Remove plug from the front of the LubriMist reservoir and fill with oil.
- **DO NOT OVERFILL!!!!**
- Overfilling will restrict the mist head and the system will not work properly.
- Start the forage harvester engine and allow the air system to charge.

- If the system is working properly, you will see what appears to be smoke or fog coming from the bearing housings and the bearing slides.
- Set the LubriMist regulator to 35 psi.

The regulator also has a water separator. This automatically drains itself periodically. The regulator will freeze and break if it is not drained at the end of season.

INSTALLATION & REMOVAL INSTRUCTIONS FOR CLIMAX SERIES C123 & C133

****IMPORTANT NOTICE****

When installing or removing any CLIMAX Keyless Locking Device (KLD), please follow these important safety standards:

1. Check to ensure that power switches are off & locked out.
2. Always wear safety glasses & appropriate protective clothing.

INSTALLATION

C123 Series

C133 Series

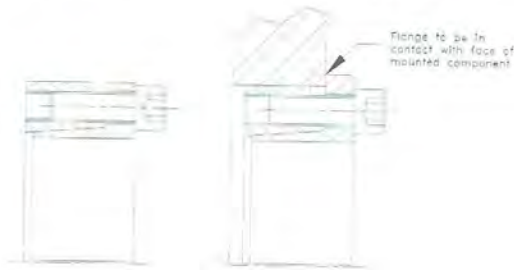

Figure 1

CLIMAX Series C123 and C133 Keyless Locking Devices are supplied with a thin coating of machine oil to achieve a coefficient of friction of 0.12 and are shipped ready for installation. As published contact pressures and torque capacities are based on this coefficient, DO NOT use Molybdenum Disulfide (e.g., Molykote, Never-Seez or similar lubricants), or synthetic lubricants with this CLIMAX KLD.

1. Check to ensure that locking screw, taper, shaft and bore contact areas are clean and thoroughly lubricated with a coating of light machine oil and that radial slits are aligned.
2. To lock out mating tapers and prevent engagement during assembly, transfer at least two or three locking screws into integrated jacking holes in front flange (see Figure 2).
3. Insert CLIMAX Series C123 or C133 into component bore, then transfer screws used to separate collars back to their original position. Note that for Series C133 the flange must be in contact with the face of the mounted component (see Figure 1).
4. Tighten all locking screws by hand until screw heads are in contact with the front face of the flange.
5. Use a properly calibrated torque wrench (we recommend the CCM Series from Sturtevant Richmond) and set it approximately 5% higher than our specified tightening torque M_3 . Starting with a locking screw adjacent to the slit and, moving in the direction away from the slit, tighten the screws in a circular pattern, using quarter turns for each screw, several times around until quarter turns can no longer be achieved. At this point, apply the 5% overtorque for two more complete times around.
6. Reset the torque wrench to our specified tightening torque M_3 . Check to ensure that none of the locking screws turn at this torque value, otherwise reset the wrench to the 5% higher value and repeat Step 5 for one or two more complete passes.

INSTALLATION & REMOVAL INSTRUCTIONS FOR CLIMAX SERIES C123 & C133

IMPORTANT NOTICE

When installing or removing any CLIMAX Keyless Locking Device (KLD), please follow these important safety standards:

1. Check to ensure that power switches are off & locked out.
2. Always wear safety glasses & appropriate protective clothing.

REMOVAL

C123 Series

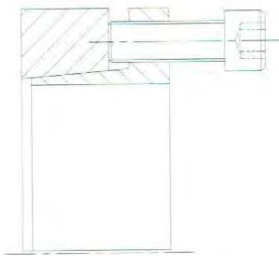

C133 Series

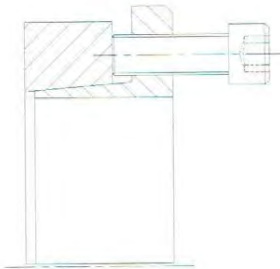

Figure 2

1. Remove all locking screws. Count the number of jacking holes in the front flange and select the same number of locking screws. The ends of these screws are to be ground flat and slightly chamfered to ease removal and prevent damage to the KLD push-off surface and/or the screw threads.
2. Ensure that axial movement of KLD collars is not restricted, as this is necessary for proper removal.
3. Using the modified screws from Step 1, insert into all jacking holes located in front flange (see Figure 2).
4. The KLD is released by evenly and gradually tightening these screws, using quarter turns for each screw, in a diametrically opposed pattern.

Locking Screw Tightening Torque M_a

Screw Size	M4	M6	M8	M10	M12	M14	M16	M18
C133 Tightening Torque M_a (ft-lb)	3.7	13	30	61	107	170	262	358
C123 Tightening Torque M_a (ft-lb)	3	10	26	51	89	140	218	299

SCHERER OIL TANK HEAD ASSEMBLY

COMPLETE ASSEMBLY: **PART# OM2000**

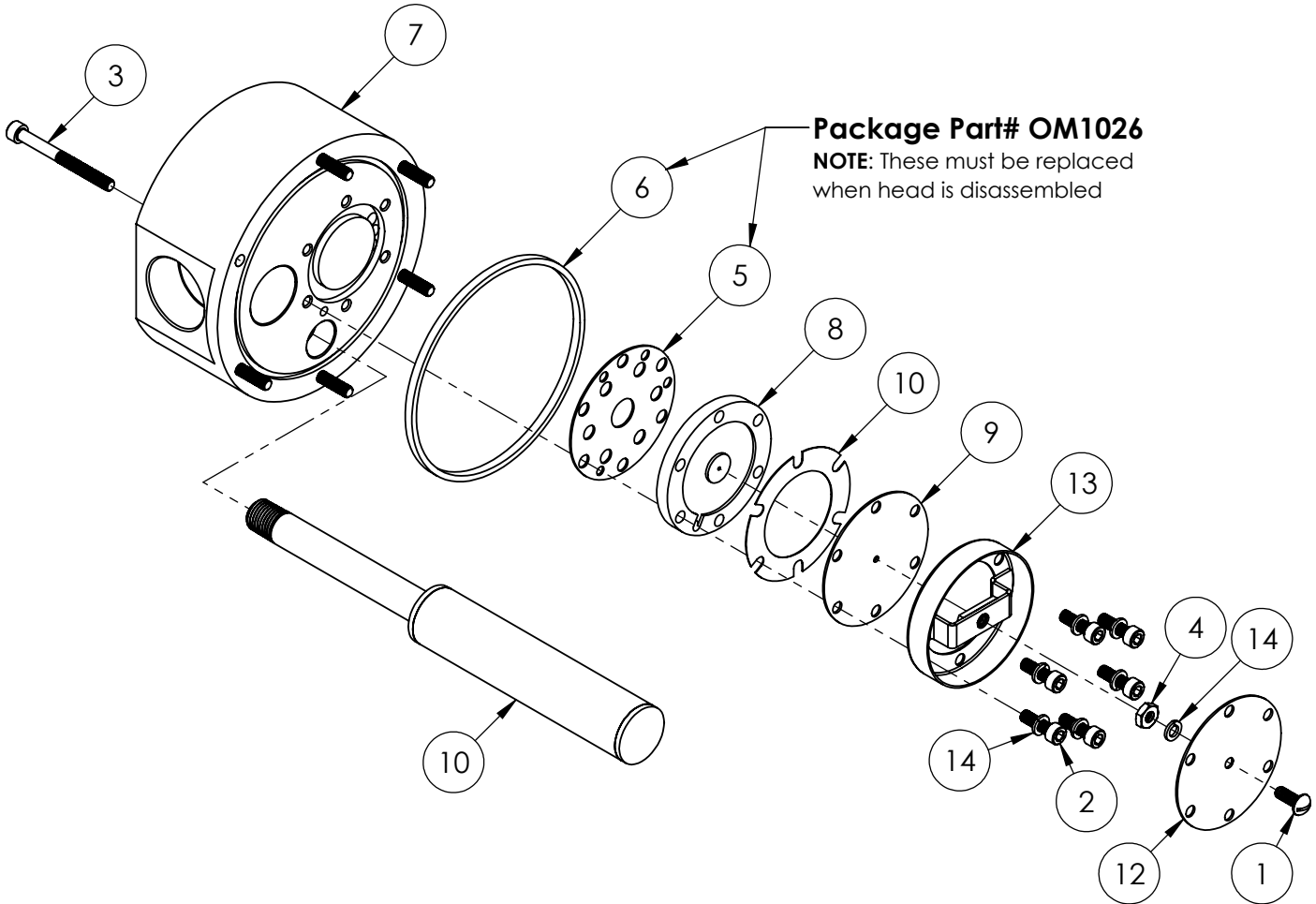

ITEM NO.	PART NUMBER	DESCRIPTION	QTY.
1	BLT10044	MACHINE SCREW	1
2	BLT10045	SOCKET HEAD CAP SCREW	6
3	BLT10048	SOCKET HEAD CAP SCREW	6
4	NUT10011	MACHINE HEX NUT	1
5	OM1026.1	VORTEX PLATE GASKET	1
6	OM1026.2	HEAD GASKET	1
7	OM2001	MIST HEAD	1
8	OM2002	VORTEX PLATE	1
9	OM2003	MISTER OIL PLATE	1
10	OM2004	OIL PLATE SPACER	1
10	OM2007	SIPHON TUBE	1
12	OM2008	IMPINGEMENT PLATE	1
13	OM2009	BAFFLE ASSEMBLY	1
14	WSH10006	LOCK WASHER	7

SCHERER OIL TANK HEAD CLEANING

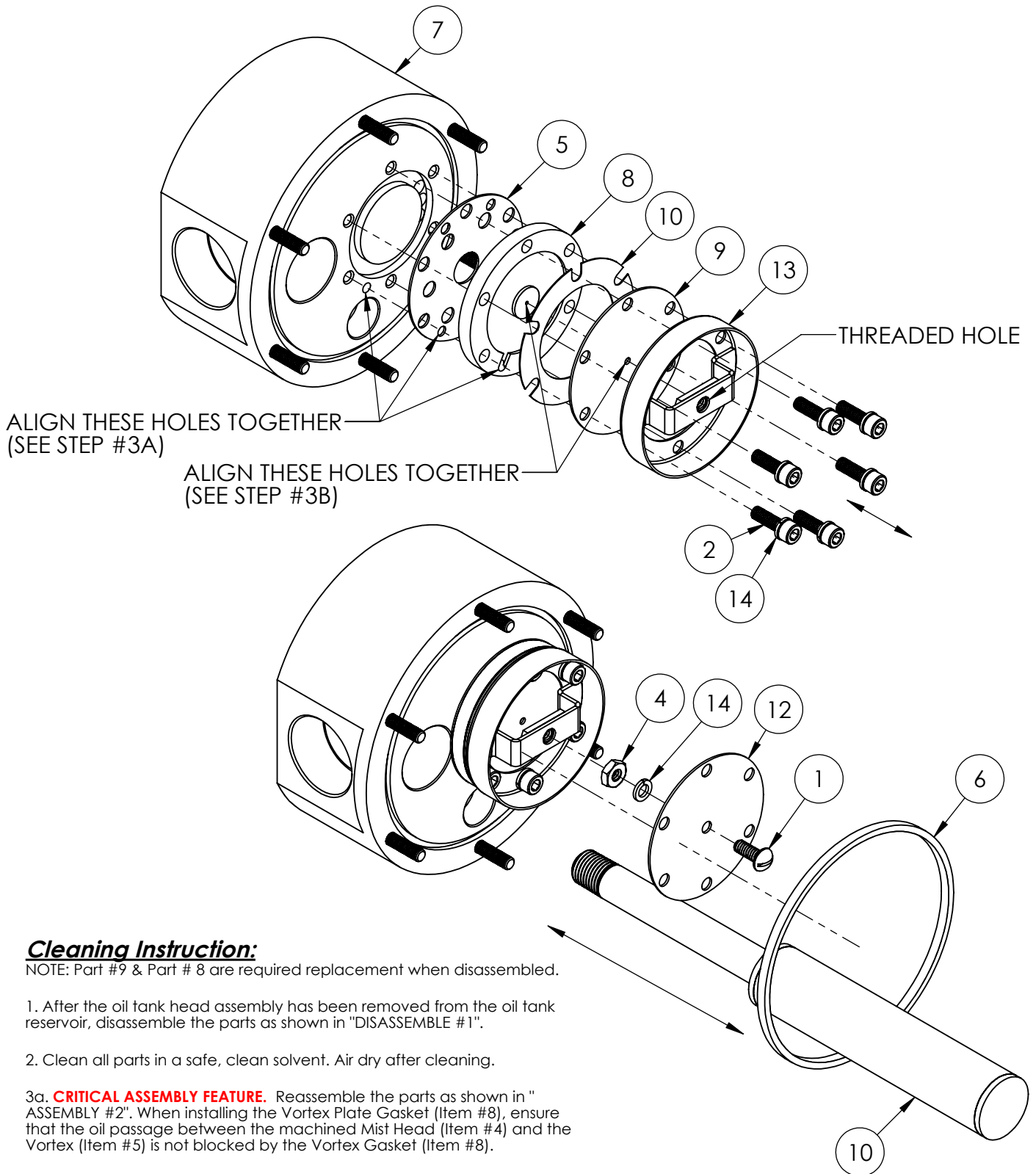

Cleaning Instruction:

NOTE: Part #9 & Part #8 are required replacement when disassembled.

1. After the oil tank head assembly has been removed from the oil tank reservoir, disassemble the parts as shown in "DISASSEMBLE #1".

2. Clean all parts in a safe, clean solvent. Air dry after cleaning.

3a. **CRITICAL ASSEMBLY FEATURE.** Reassemble the parts as shown in "ASSEMBLY #2". When installing the Vortex Plate Gasket (Item #8), ensure that the oil passage between the machined Mist Head (Item #4) and the Vortex (Item #5) is not blocked by the Vortex Gasket (Item #8).

3B. **CRITICAL ASSEMBLY FEATURE.** Ensure that the center holes of the Vortex (Item #5) and Oil Plate (Item #6) are axially aligned by viewing them through the threaded hole of Baffle Assembly (Item #12).

4. Once the assembly is aligned, torque the 6 screws (Item #2) to 22 in-lbs.

5. Install the Impingement Plate (Item #11) as shown in "ASSEMBLY #3".

6. Install Head Gasket (Item #2) when installing the Mist Head onto the oil reservoir.